

Virtual City Council Meetings Details

Due to the Covid-19 “Coronavirus” pandemic, regular and special meetings of the City Council will continue to be held in a “virtual” meeting room. This will allow for safe participation by elected officials, departmental managers, and any citizen interested in attending.

Cisco WebEx hosts the virtual Council Chamber. Join the meetings using the information shown below.

Visit the [City Council Meeting page](#) to view the agenda for upcoming meetings.

The next City Council meeting is scheduled for **6:20 PM – 8:50 PM** on **Tuesday, December 21, 2021**.

December 21, 2021 Virtual Meeting Details: Special & Regular City Council Meeting

At no sooner than 6:20 p.m., visit the Cisco WebEx meeting site by clicking the link below.

<https://bit.ly/MattoonCC211221>

Meeting number (access code): 2557 503 2938

Meeting password: 20819

Additional Instructions

Join meetings by telephone by **dialing 415-655-0001** and use the **meeting number** and **password** shown above.

Participants may be muted when initially connected to the meeting.

If using a phone to call in, you can press ***6** to unmute and mute yourself when public comment is invited.

If you wish to be heard during the public comment portion of the meeting or wish to comment during the discussion period on an open motion, you need to send your comments in advance to the City Clerk’s office. Your comments will be read into the record, or you will be called upon to speak at the appropriate time. Contact the City Clerk’s office before 4:00 p.m. on the day of the meeting by calling 217-235-5654 or by sending an email message to cityclerk@mattoonillinois.org. NOTE: All those speaking during the meeting must first identify themselves by providing their full name for the record.

**SPECIAL MEETING – PUBLIC HEARING
CITY OF MATTOON, ILLINOIS
CITY COUNCIL AGENDA
December 21, 2021
6:20 PM**

6:20 PM BUSINESS MEETING

Pledge of Allegiance

Roll Call

PRESENTATIONS, PETITIONS AND COMMUNICATIONS

This portion of the City Council meeting is reserved for persons who desire to address the Council. The Illinois Open Meetings Act mandates that the City Council may NOT take action on comments received on matters that have not been identified on this agenda, but the Council may direct staff to address the topic or refer the matter for action on the agenda for another meeting. Persons addressing the Council are requested to limit their presentations to three minutes and to avoid repetitious comments. We would also ask you to state your name and address for the record as well as stand when speaking.

PUBLIC HEARING - Close-out BCBS grant hearing

Adjourn

**CITY OF MATTOON, ILLINOIS
CITY COUNCIL AGENDA
December 21, 2021
6:30 PM**

6:30 PM BUSINESS MEETING

Pledge of Allegiance

Roll Call

Electronic Attendance

CONSENT AGENDA:

Items listed on the Consent Agenda are considered to be routine in nature and will be enacted by one motion. No separate discussion of these items will occur unless a Council Member requests the item to be removed from the Consent Agenda. If an item is removed from the Consent Agenda, it will be considered elsewhere on the agenda for this meeting. Prior to asking for a motion to approve the Consent Agenda, the Mayor will ask if anyone desires to remove an item from the Consent Agenda for public discussion.

- 1. Minutes of the Regular Meeting December 7, 2021.**
- 2. Bills and Payroll for the first half of December, 2021.**

PRESENTATIONS, PETITIONS AND COMMUNICATIONS

This portion of the City Council meeting is reserved for persons who desire to address the Council. The Illinois Open Meetings Act mandates that the City Council may NOT take action on comments received on matters that have not been identified on this agenda, but the Council may direct staff to address the topic or refer the matter for action on the agenda for another meeting. Persons addressing the Council are requested to limit their presentations to three minutes and to avoid repetitious comments. We would also ask you to state your name and address for the record as well as stand when speaking.

Acknowledging the retirement of Delbert Hamilton with more than 24 years of service in the Mattoon Parks Department on December 31, 2021.

NEW BUSINESS

- 1. Motion – Approve Council Decision Request 2021-2201: Approving the promotion of Police Sergeant Michael A. Johnson to the rank of Lieutenant, effective December 25, 2021, due to the retirement of Lt. Sweeney. (Hall)**
- 2. Motion – Approve Council Decision Request 2021-2202: Approving the appointment of Officer Robert Agney to regular employment status with the Mattoon Police Department after successful completion of his probationary period effective 01/02/2022. (Hall)**

3. Motion – Adopt Resolution No. 2021-3168: Approving the supplemental funding of Motor Fuel Tax funds in the amount of \$1,496.59 for the intersection projects located at 12th and Dewitt Avenue and Logan and DeWitt Avenue; and authorizing the city clerk to sign the document. (Phipps) 19-00314-00-PP

4. Motion – Approve Council Decision Request 2021-2203: Awarding the bid in the amount of \$47,882.50 to Consolidated Communications for the Depot Video Surveillance System. (Closson)

5. Motion – Adopt Resolution No. 2021-3169: Approving the continuance of a Local State of Emergency due to the Coronavirus (COVID – 19). (Hall)

DEPARTMENT REPORTS:

**CITY ADMINISTRATOR/COMMUNITY DEVELOPMENT
CITY ATTORNEY
CITY CLERK
FINANCE
PUBLIC WORKS
FIRE
POLICE
ARTS AND TOURISM**

COMMENTS BY THE COUNCIL

Adjourn

CONSENT AGENDA ITEMS:

UNAPPROVED MINUTES:

Regular Meeting – December 07, 2021

The City Council of the City of Mattoon held a Regular City Council meeting in the Council Chambers of City Hall on December 7, 2021. Mayor Hall presided and called the meeting to order at 6:30 p.m.

Mayor Hall led the Pledge of Allegiance.

Mayor Hall called for a moment of silence in remembrance of the Attack on Pearl Harbor.

The following members of the Council answered roll call physically present in person: YEA Commissioner Jim Closson, YEA Commissioner Dave Cox, YEA Commissioner Sandra Graven, YEA Commissioner David Phipps, and YEA Mayor Rick Hall.

Also physically present were City personnel in person: City Administrator Kyle Gill, City Attorney Dan C. Jones, Finance Director/Treasurer Beth Wright, Public Works Director Dean Barber, Fire Chief Jeff Hilligoss, Police Chief Sam Gaines, and City Clerk Susan O'Brien.

CONSENT AGENDA

Mayor Hall seconded by Commissioner Graven moved to approve the consent agenda consisting of minutes of the Regular Meeting of November 16, 2021, bills and payroll for the last half of November, 2021.

Bills and payroll for the last half of November, 2021

General Fund

Payroll		\$	344,837.88
Bills		\$	715,313.19
	Total	\$	<u>1,060,151.07</u>

Hotel Tax Administration

Payroll		\$	3,609.34
Bills		\$	834.54
	Total	\$	<u>4,443.88</u>

Festival Management Fund

Bills		\$	11,843.44
	Total	\$	<u>11,843.44</u>

Insurance & Tort Jdgmnt

Bills		\$	18,970.00
	Total	\$	<u>18,970.00</u>

Midtown TIF Fund

Bills		\$	15,992.10
	Total	\$	<u>15,992.10</u>

<u>Capital Project Fund</u>		
Bills		\$ 29,530.45
	Total	\$ 29,530.45
<u>I-57 East TIF Dist</u>		
Bills		\$ 247.50
	Total	\$ 247.50
<u>Water Fund</u>		
Payroll		\$ 43,594.49
Bills		\$ 96,821.22
	Total	\$ 140,415.71
<u>Sewer Fund</u>		
Payroll		\$ 40,195.69
Bills		\$ 1,243,762.96
	Total	\$ 1,283,958.65
<u>Health Insurance Fund</u>		
Bills		\$ 188,807.37
	Total	\$ 188,807.37
<u>Motor Fuel Tax Fund</u>		
Bills		\$ 31,251.14
	Total	\$ 31,251.14

Mayor Hall declared the motion to approve the consent agenda carried by the following vote: YEA Commissioner Closson, YEA Commissioner Cox, YEA Commissioner Graven, YEA Commissioner Phipps, YEA Mayor Hall.

PRESENTATIONS, PETITIONS AND COMMUNICATIONS

Acknowledging the retirement of Parks Maintenance Worker Joel Pittman with more than 24 years of service with the Parks/Lakes/Cemetery Department on November 27, 2021. Commissioner Closson provided a background and accolades of Mr. Pittman's career with the City. Mr. Pittman thanked the Council, Administrator Gill, Superintendent Stretch and his wife.

Friends of Lake Mattoon – Katie O'Dell

Mrs. O'Dell, President of Friends of Lake Mattoon and resides at 1097 N 3150E Road, Windsor, and Vice President Jette Carman with Secretary Lorreta Cain presented the Council with a background of the Friends of Lake Mattoon, membership, purpose, improvements made, fundraisers and donations; and requested the City to work with them on future projects. Mayor Hall opened the floor for questions. Commissioner Closson stated the City would meet with the Friends of Lake Mattoon to see what could be done. Mayor Hall appreciated everything the group does for the Lake. Commissioner Cox noted the dedicated group had done a lot of good work.

Presentation: Audit – Doehring, Winders & Company, LLC

Mr. Larry Nichols of Doehring, Winders & Company presented the final audit and highlighted the report including the government-wide statements, single audit, opinions, Federally-funded programs/notes/disclosures, city-wide statements, pensions, OPEB, deficit and council communication letter; and noted providing assistance with the TIF reports, Annual Comptroller Report and Department of Insurance Annual Reports. Mayor Hall opened the floor for questions. Mayor Hall noted the audit covers the year that ended eight months prior, making

some improvements, helps plan for the future and appreciated the auditors' time. Mr. Nichols acknowledged good help from Director & Treasurer Wright, Director Barber and Administrator Gill.

Mayor Hall opened the floor for Public comments. Mr. Alex Walker questioned the resuming of the ambulance services. Mayor Hall noted plans to return to previous status per the Court decision, but not overnight.

NEW BUSINESS

Commissioner Graven seconded by Commissioner Cox moved to adopt Special Ordinance No. 2021-1797, levying taxes for all corporate purposes for the fiscal year beginning May 1, 2021 and ending April 30, 2022.

CITY OF MATTOON, ILLINOIS

SPECIAL ORDINANCE NO. 2021-1797

AN ORDINANCE LEVYING TAXES FOR ALL CORPORATE PURPOSES FOR THE CITY OF MATTOON, COLES COUNTY, ILLINOIS, FOR THE FISCAL YEAR BEGINNING MAY 1, 2021 AND ENDING APRIL 30, 2022

BE IT ORDAINED by the Mayor and City Council of the City of Mattoon, Coles County, Illinois:

Section 1. Assumed Equalized Assessed Valuation. The corporate authorities have assumed the Equalized Assessed Valuation (EAV) of property within the municipality will remain the same at \$209,661,877.

Section 2. Tax Levy. The amount hereinafter set forth, or so much thereof as may be authorized by law, and the same are hereby levied upon all property subject to taxation within the municipality as that property is assessed and equalized for the current year, to defray expenses and liabilities for the City of Mattoon, Coles County, Illinois, for the fiscal year beginning May 1, 2021 and ending April 30, 2022. The total property tax levy extension is attached hereto and marked as "Exhibit A" and incorporated herein by reference.

Section 3. Maximum Rates for Certain Services. If the equalized assessed value of the municipality ends up lower or higher than the value anticipated by this ordinance, the Coles County Clerk is petitioned to levy the maximum property tax rate authorized by law for General Corporate, Police Protection and Fire Protection.

Section 4. Tax Abatement for General Obligation Bonds. Since alternative revenue sources will be sufficient to pay debt service on the City of Mattoon's General Obligation Bonds, the 2021 tax levy (to be received in 2022) is hereby abated for the following General Obligation Bonds:

<u>Issue</u>	<u>Tax Levy Years</u>	<u>Bond Ordinance Number</u>
Series 2017A General Obligation Refunding Bonds	2017 thru 2027	Ordinance 2017-5397
Series 2017B General Obligation Refunding Bonds	2017 thru 2027	Ordinance 2017-5398

The levy for paying principal and interest on these bonds shall only be abated for the 2021 tax levy. In all other respects, the ordinances that authorized the foregoing bonds shall continue in effect according to the express terms thereof.

Section 5. Amount to be Raised by Tax Levy. The amount to be levied for each purpose is placed in a separate column under the heading “Amount to be Raised by Tax Levy”, which appears over same being as follows, to wit:

	<u>Amount Budgeted</u>	<u>Amount To Be Received from Other Sources</u>	<u>Amount To Be Raised By Tax Levy</u>
General Fund			
General Government	1,098,348	1,098,348	-0-
Public Safety	13,274,049	8,839,021	4,435,028
Public Works	1,182,219	1,182,219	-0-
Health & Welfare	1,596,476	1,596,476	-0-
Culture & Recreation	1,058,377	1,058,377	-0-
Economic Development	50,000	50,000	-0-
Debt Service	500	500	-0-
Other Financing Uses	<u>1,255,039</u>	<u>1,255,039</u>	<u>-0-</u>
Total General Fund	\$ 19,515,008	\$ 15,079,980	\$ 4,435,028

Statutory Authority:

General Corporate Tax (65 ILCS 5/8-3-1): 0.25 Limit	-0-
Fire Protection (65 ILCS 5/11-7-1): 0.15 Limit	-0-
Police Protection (65 ILCS 5/11-1-3): 0.15 Limit	-0-
Parks (65 ILCS 5/11-98-1): 0.075 Limit	-0-
Firemen's Pension (40 ILCS 5/4-118) No Limit	2,443,925
Firemen's Pension (35 ILCS 200/18-185) No Limit	42,143
Policemen's Pension (40 ILCS 5/3-125) No Limit	<u>1,948,960</u>
	\$ 4,435,028

	<u>Amount Budgeted</u>	<u>Amount To Be Received from Other Sources</u>	<u>Amount To Be Raised By Tax Levy</u>
Other Governmental Funds:			
Library Fund	\$ 617,450	\$ 135,228	\$ 482,222
Motor Fuel Tax Fund	1,461,916	1,461,916	-0-
Hotel & Motel Tax Fund	327,748	327,748	-0-
Festival Management Fund	153,925	153,925	-0-
Mobile Equipment Fund	708,613	708,613	-0-
Insurance & Tort Judgment Fund	1,021,035	1,021,035	-0-
Home Rehab Grant Fund	500,000	500,000	-0-
Revolving Loan Fund	20,044	20,044	-0-
Midtown TIF Fund	1,345,750	1,345,750	-0-
East I-57 TIF Fund	155,600	155,600	-0-

East I-57 Business District Fund	13,791	13,791	-0-
South Route 45 TIF District Fund	70,586	70,586	-0-
South Route 45 Business District Fund	0	0	-0-
Broadway East TIF District Fund	89,040	89,040	-0-
Broadway East Business District Fund	348,158	348,158	-0-
Capital Improvement Fund	<u>1,222,826</u>	<u>1,222,826</u>	<u>-0-</u>
Total Other Governmental Funds	\$8,056,482	\$7,574,260	\$ 482,222

Statutory Authority:

Library (75 ILCS 5/3-1, 5/3-4, 5/3-7) 0.23 Limit \$ 482,222

	<u>Amount Budgeted</u>	<u>Amount To Be Received from Other Sources</u>	<u>Amount To Be Raised By Tax Levy</u>
Enterprise Funds:			
Water Fund	\$ 4,385,527	\$ 4,385,527	-0-
Sewer Fund	<u>13,525,575</u>	<u>13,525,575</u>	<u>-0-</u>
Total Enterprise Funds	\$ 17,911,102	\$ 17,911,102	-0-
All Fund Totals	\$ 45,482,592	\$40,565,342	\$4,917,250

Section 6. The City Clerk shall make and file with the Clerk of Coles County, on or before the last Tuesday in December, a duly certified copy of this ordinance.

Section 7. If any section, subdivision or sentence of this ordinance shall for any reason is held invalid or to be unconstitutional, such decision shall not affect the validity of the remaining part of this ordinance.

Section 8. This ordinance shall be in full force and effect after its adoption, as provided by law. Upon motion by Commissioner Graven, seconded by Commissioner Cox, adopted this 7th day of December, 2021, by a roll call vote, as follows:

AYES (Names): Commissioner Closson, Commissioner Cox,
Commissioner Graven, Commissioner Phipps, Mayor Hall

NAYS (Names): None

ABSENT (Names) None

Approved this 7th day of December, 2021.

/s/Rick Hall
Rick Hall, Mayor
City of Mattoon, Coles County, Illinois

ATTEST:
/s/Susan J. O'Brien
Susan J. O'Brien, City Clerk

APPROVED AS TO FORM:
/s/Daniel C. Jones
Daniel C. Jones, City Attorney

Recorded in the Municipality's Records on December 7, 2021.

Mayor Hall opened the floor for discussion. Director & Treasurer Wright commented on the prior extension after PTELL with the preliminary levy at 5% increase, PTELL caps, anticipated receiving \$80,000 more than previous year which equated to a \$15.78 increase for a \$100,000 home, and Fire and Police pensions at \$5.5 million. Mayor Hall commented on the pension increases of \$200,000 from last year. Mayor Hall called for additional comments with no response.

Mayor Hall declared the motion carried by the following vote: YEA Commissioner Closson, YEA Commissioner Cox, YEA Commissioner Graven, YEA Commissioner Phipps, YEA Mayor Hall.

Mayor Hall seconded by Commissioner Closson moved to adopt Resolution No. 2021-3165, approving an update to the City's Equal Employment Opportunity Plan (EEO).

CITY OF MATTOON, ILLINOIS

RESOLUTION NO. 2021-3165

A RESOLUTION APPROVING AN UPDATE TO THE CITY'S EQUAL EMPLOYMENT OPPORTUNITY PLAN

WHEREAS, the purpose of an Equal Employment Opportunity Plan is to insure full and equal participation of men and women regardless of race or national origin in the workforce of an agency that receives federal grant funds; and

WHEREAS, it is now necessary for the City Council to update its Equal Employment Opportunity Plan to maintain continued eligibility for federal grants.

NOW, THEREFORE, BE IT RESOLVED BY THE CITY COUNCIL FOR THE CITY OF MATTOON, COLES COUNTY, ILLINOIS that the Mayor is authorized to sign a document indicating the Council's approval of an update to the City of Mattoon's "Equal Employment Opportunity Plan", a copy of which is attached hereto and incorporated by reference.

Upon motion by Mayor Hall, seconded by Commissioner Closson, adopted this 7th day of December, 2021, by a roll call vote, as follows:

AYES (Names): Commissioner Closson, Commissioner Cox,
Commissioner Graven, Commissioner Phipps, Mayor Hall
NAYS (Names): None
ABSENT (Names): None

Approved this 7th day of December, 2021.

/s/Rick Hall
Rick Hall, Mayor
City of Mattoon, Coles County, Illinois

ATTEST:

APPROVED AS TO FORM:

/s/Susan J. O'Brien

Susan J. O'Brien, City Clerk

/s/Daniel C. Jones

Daniel C. Jones, City Attorney

Recorded in the Municipality's Records on December 7, 2021.

Mayor Hall opened the floor for comments. Administrator Gill noted the biennial update of the Plan, which included demographics from the 2020 Census and need for diversity.

Mayor Hall declared the motion carried by the following vote: YEA Commissioner Closson, YEA Commissioner Cox, YEA Commissioner Graven, YEA Commissioner Phipps, YEA Mayor Hall.

Mayor Hall seconded by Commissioner Graven moved to adopt Special Ordinance No. 2021-1798, granting a special use located at 3516 Powell Lane allowing for a Christian school. Petitioner: Maranatha Baptist Church

CITY OF MATTOON, ILLINOIS

SPECIAL ORDINANCE NO. 2021-1798

AN ORDINANCE GRANTING SPECIAL USE AT 3516 POWELL LANE TO ALLOW A CHRISTIAN SCHOOL

WHEREAS, there has been filed a written Petition for Maranatha Academy requesting a Special Use of the parcels legally described as:

PARCEL I:

ALL THAT PART OF LOT 2 OF THE F.V. NOYES SUBDIVISION OF THE NORTH HALF OF SECTION 15, TOWNSHIP 12 NORTH RANGE 7 EAST OF THE THIRD PRINCIPAL MERIDIAN, COLES COUNTY ILLINOIS WHICH LIES NORTH OF THE CENTER LINE OF S.B.I. ROUTE 121 AS EXISTING ON JULY 27, 1963 EXCEPT THE EAST 124.0 FEET HEREOF; AND ALSO EXCEPTING THE FOLLOWING DESCRIBED TRACT: FROM THE NORTHEAST CORNER OF SAID SECTION, MEASURE SOUTHERLY PERPENDICULARLY TO THE EXISTING CENTER LINE OF DEWITT AVENUE FOR 6.62 FEET; THENCE MEASURE WESTERLY ON THE EXISTING CENTERLINE OF POWELL LANE FOR 1,119.64 FEET TO THE PLACE OF BEGINNING; THENCE DEFLECTING 90 DEGREES 30 MINUTES 04 SECONDS TO THE LEFT FROM THE LAST DESCRIBED COURSE SOUTHERLY ALONG THE EAST LINE OF THE ABOVE MENTIONED PROPERTY FOR 80.61 FEET; THENCE DEFLECTING 45 DEGREES 19 MINUTES 43 SECONDS TO THE RIGHT SOUTHWESTERLY FOR 90.44 FEET; THENCE DEFLECTING 67 DEGREES 58 MINUTES 16 SECONDS TO THE LEFT SOUTHEASTERLY FOR 73.04 FEET TO THE NORTHERLY RIGHT OF WAY LINE OF EXISTING F.A. ROUTE 33 (S.B.I. ROUTE 121); THENCE DEFLECTING 46 DEGREES 14 MINUTES 01 SECONDS TO THE RIGHT SOUTHERLY FOR 40.00 FEET; THENCE DEFLECTING 90 DEGREES 00 MINUTES 00 SECONDS TO THE RIGHT TANGENT OF A CURVE TO THE RIGHT HAVING A RADIUS OF 1,211.2 FEET, AND MEASURE NORTHWESTERLY AROUND SAID CURVE ON THE CENTERLINE OF EXISTING F.A. ROUTE 33 FOR 46.70 FEET;

THENCE NORTHWESTERLY TANGENT TO THE LAST DESCRIBED CURVE ON SAID CENTERLINE FOR 281.70 FEET; THENCE NORTHWESTERLY AROUND A CURVE TO THE LEFT, TANGENT TO THE LAST DESCRIBED COURSE, HAVING A RADIUS OF 1,300.5 FEET ON SAID CENTERLINE FOR 43.57 FEET; THENCE DEFLECTING 90 DEGREES 00 MINUTES 00 SECONDS TO THE RIGHT FROM A TANGENT TO THE LAST DESCRIBED CURVE NORTHEASTERLY FOR 40.00 FEET; THENCE DEFLECTING 21 DEGREES 52 MINUTES 03 SECONDS TO THE LEFT NORTHERLY ON THE EASTERLY RIGHT OF WAY LINE OF EXISTING F.A. ROUTE 33 FOR 60.99 FEET; THENCE DEFLECTING 89 DEGREES 29 MINUTES 38 SECONDS TO THE RIGHT EASTERLY ON THE EXISTING CENTERLINE OF POWELL LANE FOR 369.58 FEET TO THE PLACE OF BEGINNING.

SAID TRACT SO SURVEYED MORE PARTICULARLY DESCRIBED AS FOLLOWS: COMMENCING AT THE NORTHEAST CORNER OF SECTION 15, TOWNSHIP 12 NORTH RANGE 7 EAST OF THE THIRD PRINCIPAL MERIDIAN, THENCE AZIMUTH 271 DEGREES 57 MINUTES 52 SECONDS ALONG THE NORTHLINE OF SAID SECTION 15, A DISTANCE OF 1,119.20 FEET; THENCE AZIMUTH 180 DEGREES 31 MINUTES 25 SECONDS A DISTANCE OF 82.26 FEET TO THE SOUTHEASTERLY RIGHT OF WAY LINE OF THE DEWITT AVENUE SPUR AND THE PLACE OF BEGINNING; THENCE CONTINUING AZIMUTH 180 DEGREES 31 MINUTES 25 SECONDS A DISTANCE OF 146.03 FEET TO THE NORTHERLY RIGHT OF WAY LINE OF FEDERAL AID ROUTE 33 (ILLINOIS ROUTE 121) THENCE ALONG THE SAID NORTHERLY RIGHT OF WAY LINE, ALONG A CURVE TO THE RIGHT, WHOSE RADIUS IS 1,171.20 FEET, AN ARC DISTANCE OF 38.76 FEET TO AN EXISTING IRON PIN MARKING THE INTERSECTION OF THE SAID NORTHERLY RIGHT OF WAY LINE WITH THE EASTERLY RIGHT OF WAY LINE OF THE DEWITT AVENUE SPUR, THENCE AZIMUTH 337 DEGREES 38 MINUTES 50 SECONDS ALONG THE SAID EASTERLY RIGHT OF WAY LINE, A DISTANCE OF 72.95 FEET ACTUAL (73.04 FEET RECORD) TO AN EXISTING IRON PIN MARKING THE INTERSECTION OF THE SAID EASTERLY RIGHT OF WAY LINE WITH THE SOUTHEASTERLY RIGHT OF WAY LINE OF THE SAID DEWITT AVENUE SPUR; THENCE AZIMUTH 45 DEGREES 48 MINUTES 52 SECONDS ALONG THE SOUTHEASTERLY RIGHT OF WAY LINE OF SAID SPUR, A DISTANCE OF 90.44 FEET ACTUAL AND RECORD TO THE PLACE OF BEGINNING EXCEPTING THEREFROM ANY INTEREST OR ESTATE IN THE MINERALS UNDERLYING THE SURFACE OF THE LAND WHICH MAY HAVE BEEN HERETOFORE CONVEYED OR RESERVED AND ALL RIGHTS AND EASEMENTS IN FAVOR OF ANY SUCH MINERAL INTEREST OR ESTATE.

PARCEL II:

BEGINNING AT THE SOUTHEAST CORNER OF THE SOUTHWEST 1/4 OF THE SOUTHEAST 1/4 OF SECTION 10, TOWNSHIP 12 NORTH RANGE 7 EAST OF THE THIRD PRINCIPAL MERIDIAN AS NOW ESTABLISHED; THENCE NORTH ALONG THE EAST LINE OF SAID SOUTHWEST 1/4 OF THE SOUTHEAST 1/4, 505 FEET; THENCE WEST PARALLEL TO THE SOUTH LINE OF SAID SOUTHWEST 1/4 OF THE SOUTHEAST 1/4, 400 FEET; THENCE SOUTH PARALLEL TO THE EAST LINE OF SAID SOUTHWEST 1/4 OF THE SOUTHEAST 1/4 505 FEET; THENCE EASTERLY TO THE PLACE OF BEGINNING.

SAID TRACT SO SURVEYED MORE PARTICULARLY DESCRIBED AS FOLLOWS: BEGINNING AT THE SOUTHEAST CORNER OF THE SOUTHWEST 1/4 OF THE SOUTHEAST 1/4 OF SECTION 10, TOWNSHIP 12 NORTH, RANGE 7 EAST OF THE THIRD PRINCIPAL MERIDIAN, THENCE AZIMUTH 271 DEGREES 51 MINUTES 52 SECONDS ALONG THE SOUTH LINE OF SAID SECTION 10, A DISTANCE OF 399.37

FEET ACTUAL (400 FEET RECORD); THENCE AZIMUTH 0 DEGREES 05 SECONDS 03 MINUTES A DISTANCE OF 505.25 FEET ACTUAL (505 FEET RECORD); THENCE AZIMUTH 91 DEGREES 58 MINUTES 09 SECONDS A DISTANCE OF 399.29 FEET ACTUAL (400 FEET RECORD) TO THE EAST LINE OF THE SOUTHWEST 1/4 OF THE SOUTHEAST 1/4 OF SAID SECTION 10, AS ESTABLISHED BY PREVIOUS SURVEY; THENCE AZIMUTH 180 DEGREES 04 MINUTES 28 SECONDS ALONG THE SAID EAST LINE A DISTANCE OF 505.22 FEET ACTUAL (505 FEET RECORD) TO THE PLACE OF BEGINNING, IN COLES COUNTY, ILLINOIS.

EXCEPTING THEREFROM ANY INTEREST OR ESTATE IN THE MINERALS UNDERLYING THE SURFACE OF THE LAND WHICH MAY HAVE BEEN HERETOFORE CONVEYED OR RESERVED AND ALL RIGHTS AND EASEMENTS IN FAVOR OF ANY SUCH MINERAL INTEREST OR ESTATE.

PARCEL III:

BEGINNING AT THE SOUTHWEST CORNER OF THE SOUTHEAST 1/4 OF THE SOUTHEAST 1/4 OF SECTION 10, TOWNSHIP 12 NORTH RANGE 7 EAST OF THE THIRD PRINCIPAL MERIDIAN, COLES COUNTY, ILLINOIS; THENCE NORTH 355 FEET; THENCE EAST 240 FEET; THENCE SOUTH 355 FEET; THENCE WEST 240 FEET TO THE PLACE OF BEGINNING.

SAID TRACT SO SURVEYED MORE PARTICULARLY DESCRIBED AS FOLLOWS: BEGINNING AT THE SOUTHWEST CORNER OF THE SOUTHEAST 1/4 OF THE SOUTHEAST 1/4 OF SECTION 10 TOWNSHIP 12 NORTH RANGE 7 EAST OF THE THIRD PRINCIPAL MERIDIAN, THENCE AZIMUTH 0 DEGREES 04 MINUTES 28 SECONDS ALONG THE WEST LINE OF THE SOUTHEAST 1/4 OF THE SOUTHEAST 1/4 OF SAID SECTION 10, AS ESTABLISHED BY PREVIOUS SURVEY, A DISTANCE OF 354.86 FEET ACTUAL (355 FEET RECORD); THENCE AZIMUTH 91 DEGREES 57 MINUTES 52 SECONDS A DISTANCE OF 241.21 FEET ACTUAL (240 FEET RECORD) THENCE AZIMUTH 179 DEGREES 58 MINUTES 05 SECONDS A DISTANCE OF 354.89 FEET ACTUAL (355.0 RECORD) TO THE SOUTH LINE OF SAID SECTION 10; THENCE AZIMUTH 271 DEGREES 57 MINUTES 52 SECONDS ALONG THE SAID SOUTH LINE A DISTANCE OF 241.87 FEET ACTUAL (240 FEET RECORD) TO THE PLACE OF BEGINNING.

EXCEPTING THEREFROM ANY INTEREST OR ESTATE IN THE MINERALS UNDERLYING THE SURFACE OF THE LAND WHICH MAY HAVE BEEN HERETOFORE CONVEYED OR RESERVED AND ALL RIGHTS AND EASEMENTS IN FAVOR OF ANY SUCH MINERAL INTEREST OR ESTATE.

PARCEL IV:

BEGINNING AT A POINT 355 FEET NORTH OF THE SOUTHWEST CORNER OF THE SOUTHEAST 1/4 OF THE SOUTHEAST 1/4 OF SECTION 10, TOWNSHIP 12 NORTH RANGE 7 EAST OF THE THIRD PRINCIPAL MERIDIAN, THENCE NORTH 150 FEET; THENCE EAST 170 FEET; THENCE SOUTH 150 FEET; THENCE WEST 170 FEET TO THE PLACE OF BEGINNING, SITUATED IN COLES COUNTY ILLINOIS.

SAID TRACT SO SURVEYED MORE PARTICULARLY DESCRIBED AS FOLLOWS: COMMENCING AT THE SOUTHWEST CORNER OF THE SOUTHEAST 1/4 OF THE SOUTHEAST 1/4 OF SECTION 10, TOWNSHIP 12 NORTH RANGE 7 EAST OF THE THIRD PRINCIPAL MERIDIAN, THENCE AZIMUTH 0 DEGREES 04 MINUTES 28 SECONDS ALONG THE WEST LINE OF THE SOUTHEAST 1/4 OF THE SOUTHEAST 1/4 OF SAID SECTION 10, AS ESTABLISHED BY PREVIOUS SURVEY, A DISTANCE OF 354.86 FEET ACTUAL (355 FEET RECORD) TO THE PLACE OF BEGINNING; THENCE CONTINUING AZIMUTH 0 DEGREES 04 MINUTES 28 SECONDS ALONG SAID WEST LINE A DISTANCE OF 150.36 FEET ACTUAL (150 FEET RECORD); THENCE AZIMUTH

91 DEGREES 57 MINUTES 52 SECONDS A DISTANCE OF 170.0 FEET ACTUAL (170 FEET RECORD) THENCE AZIMUTH 180 DEGREES 04 SECONDS 28 MINUTES A DISTANCE OF 150.36 FEET ACTUAL (150 FEET RECORD) THENCE AZIMUTH 271 DEGREES 57 MINUTES 52 SECONDS A DISTANCE OF 170.0 FEET ACTUAL (170 FEET RECORD) TO THE PLACE OF BEGINNING.

EXCEPTING THEREFROM ANY INTEREST OR ESTATE IN THE MINERALS UNDERLYING THE SURFACE OF THE LAND WHICH MAY HAVE BEEN HERETOFORE CONVEYED OR RESERVED AND ALL RIGHTS AND EASEMENTS IN FAVOR OF ANY SUCH MINERAL INTEREST OR ESTATE.

PARCEL V:

PART OF THE SOUTHEAST 1/4 OF SECTION 10 TOWNSHIP 12 NORTH RANGE 7 EAST OF THE THIRD PRINCIPAL MERIDIAN MORE PARTICULARLY DESCRIBED AS FOLLOWS:

COMMENCING AT A CONCRETE NAIL AND I.D. DISK MARKING THE SOUTHEAST CORNER OF SECTION 10, TOWNSHIP 12 NORTH RANGE 7 EAST OF THE THIRD PRINCIPAL MERIDIAN, THENCE AZIMUTH 271 DEGREES 57 MINUTES 52 SECONDS ALONG THE SOUTH LINE OF SAID SECTION 10 A DISTANCE OF 1,079.47 FEET TO AN EXISTING SURVEY MARKER; THENCE AZIMUTH 359 DEGREES 58 MINUTES 05 SECONDS A DISTANCE OF 354.89 FEET TO AN EXISTING SURVEY MARKER AND THE POINT OF BEGINNING; THENCE AZIMUTH 271 DEGREES 57 MINUTES 52 SECONDS A DISTANCE OF 71.21 FEET TO AN EXISTING SURVEY MARKER, THENCE AZIMUTH 0 DEGREES 04 MINUTES 28 SECONDS A DISTANCE OF 150.36 FEET TO AN EXISTING SURVEY MARKER; THENCE AZIMUTH 91 DEGREES 57 MINUTES 52 SECONDS A DISTANCE OF 70.93 FEET TO A SURVEY MARKER SET; THENCE AZIMUTH 179 DEGREES 58 MINUTES 05 SECONDS A DISTANCE OF 150.36 FEET TO THE POINT OF BEGINNING, SITUATED IN MATTOON TOWNSHIP, COLES COUNTY, ILLINOIS.

EXCEPTING THEREFROM ANY INTEREST OR ESTATE IN THE MINERALS UNDERLYING THE SURFACE OF THE LAND WHICH MAY HAVE BEEN HERETOFORE CONVEYED OR RESERVED AND ALL RIGHTS AND EASEMENTS IN FAVOR OF ANY SUCH MINERAL INTEREST OR ESTATE.

PIN: 07-1-00300-000, 07-1-00300-001, 07-1-00572-000

Street Address:

3516 Powell Lane
Mattoon, IL 61938

WHEREAS, said site(s) are zoned R-3, residential, which does allow the operation of said development; and

WHEREAS, the property is well suited for a Christian school; and

WHEREAS, the Planning Commission held a public hearing for the City of Mattoon, Coles County, Illinois, and has recommended that the request be granted; and

WHEREAS the City Council for the City of Mattoon, Coles County, Illinois, deems that it would be in the public interest to approve a special use to allow the operation of said Christian school.

NOW, THEREFORE, BE IT ORDAINED BY THE CITY COUNCIL FOR THE CITY OF MATTOON, COLES COUNTY, ILLINOIS, as follows:

Section 1. Pursuant to enabling authority provided at Section §159.05 of the Mattoon Code of Ordinances, the property legally described as aforesaid, be and the same is granted a special use allowing for lawful right to operate a Christian school.

Section 2. This ordinance shall be deemed published as of the day of its adoption and approval by the City Council.

Section 3. This ordinance shall be effective upon its approval as provided by law.

Section 4. The City Clerk shall make and record a duly certified copy of this ordinance with the Clerk and Recorder's Office of Coles County, Illinois.

Upon motion by Mayor Hall, seconded by Commissioner Graven, adopted this 7th day of December, 2021, by a roll call vote, as follows:

AYES (Names): Commissioner Closson, Commissioner Cox,
Commissioner, Graven, Commissioner Phipps, Mayor Hall

NAYS (Names): None

ABSENT (Names): None

Approved this 7th day of December, 2021.

/s/Rick Hall
Rick Hall, Mayor
City of Mattoon, Coles County, Illinois

ATTEST:

APPROVED AS TO FORM:

/s/Susan J. O'Brien
Susan J. O'Brien, City Clerk

/s/Dan Jones
Dan Jones, City Attorney

Recorded in the Municipality's Records on December 7, 2021.

Mayor Hall opened the floor for comments. Mr. Daniel Haifley, President and Pastor, presented information on the project and explained the project. Council inquired as to the completion date, number of students to be served, number of teachers and current number of students. President/Pastor Haifley stated the Fall of 2022 as a completion date, to accommodate 220-500 students with 25-26 teachers, and currently five teachers with helpers and 22 students. Chief Gaines noted President/Pastor Haifley was the Chaplin for the Police and Fire Departments.

Mayor Hall declared the motion carried by the following vote: YEA Commissioner Closson, YEA Commissioner Cox, YEA Commissioner Graven, YEA Commissioner Phipps, YEA Mayor Hall.

Mayor Hall seconded by Commissioner Phipps moved to approve Council Decision Request 2021-2198, ratifying the re-appointments of Terry Brotherton and Bill Standerfer to the Public Works Advisory Board with terms ending 12/31/2024.

Mayor Hall opened the floor for comments with no response.

Mayor Hall declared the motion carried by the following vote: YEA Commissioner Closson, YEA Commissioner Cox, YEA Commissioner Graven, YEA Commissioner Phipps, YEA Mayor Hall.

Commissioner Cox seconded by Commissioner Closson moved to approve Council Decision Request 2021-2199, authorizing the employment of Colton M. Piper as a probationary firefighter for the Mattoon Fire Department effective December 16, 2021 or sooner, contingent upon successful completion of background, physical and psychological exams.

Mayor Hall opened the floor for comments. Chief Hilligoss provided a background on Mr. Piper with an anticipated December 15th start date. Mr. Piper provided additional information on his background and was excited to start.

Mayor Hall declared the motion carried by the following vote: YEA Commissioner Closson, YEA Commissioner Cox, YEA Commissioner Graven, YEA Commissioner Phipps, YEA Mayor Hall.

Commissioner Cox seconded by Commissioner Phipps moved to approve Council Decision Request 2021-2200, authorizing the employment of Richard Herschberger as a probationary firefighter for the Mattoon Fire Department effective December 17, 2021 or sooner, contingent upon successful completion of background, physical and psychological exams.

Mayor Hall opened the floor for comments. Chief Hilligoss provided a background on Mr. Herschberger. Mr. Herschberger stated he looked forward to working in Mattoon.

Mayor Hall declared the motion carried by the following vote: YEA Commissioner Closson, YEA Commissioner Cox, YEA Commissioner Graven, YEA Commissioner Phipps, YEA Mayor Hall.

Commissioner Closson seconded by Commissioner Cox moved to adopt Special Ordinance No. 2021-1799, declaring real estate owned by the City located at 33 Westwood surplus and authorizing the solicitation of bids for the sale of the property.

CITY OF MATTOON, ILLINOIS
SPECIAL ORDINANCE NO. 2021-1799

A SPECIAL ORDINANCE DECLARING THE LOT AT 33 WESTWOOD (PIN 07-2-14896-000), NO LONGER NECESSARY OR REQUIRED FOR USE OF THE MUNICIPALITY AND AUTHORIZING THE SOLICITATION OF BIDS FOR THE SALE OF THE PROPERTY

WHEREAS, the City of Mattoon demolished a residential structure and placed a lien on the property at 33 Westwood in Mattoon; and

WHEREAS, the City of Mattoon later purchased the property at 33 Westwood through the County Tax Sale for \$800.00; and

WHEREAS, there inquires on purchasing the property for the construction of a residence; and

WHEREAS, the City desires to sell the property for development rather than to have the property remain vacate; and

WHEREAS, it would be in the best interest of the City to sell this property for development.

NOW, THEREFORE, BE IT RESOLVED BY THE CITY COUNCIL FOR THE CITY OF MATTOON, COLES COUNTY, ILLINOIS, as follows:

Section 1. Pursuant to procedures prescribed by state statute (65 ILCS 5/11-76-4.1), a finding is hereby made by the City Council that the following described real estate at 33 Westwood is no longer necessary or required for the use of the municipality.

Lot Thirty-three (33), of Westwood Addition to the City of Mattoon, Coles County, Illinois. (PIN 07-2-14896-000)

Section 2. The real estate described in this special ordinance is in Mattoon Township.

Section 3. The management staff of the municipality is hereby authorized solicit bids for the sale of the property. Any such contract negotiated shall be subject to ratification by the City Council.

Section 4. This ordinance shall be deemed published as of the day of its adoption and approval by the City Council.

Section 5. This ordinance shall be effective upon its approval as provided by law. Upon motion by Commissioner Closson, seconded by Commissioner Cox adopted this 7th day of December, 2021, by a roll call vote, as follows:

AYES (Names): Commissioner Closson, Commissioner Cox,
Commissioner Graven, Commissioner Phipps, Mayor Hall
NAYS (Names): None
ABSENT: (Names): None

Approved this 7th day of December, 2021.

/s/Rick Hall
Rick Hall, Mayor
City of Mattoon, Coles County, Illinois

ATTEST:
/s/Susan J. O'Brien
Susan J. O'Brien, City Clerk

APPROVED AS TO FORM:
/s/Dan C. Jones
Dan C. Jones, City Attorney

Recorded in the Municipality's Records on December 7, 2021.

Mayor Hall opened the floor for comments. Administrator Gill elaborated on the City's purchase of the property at \$800 after demolishing the structure, placing lien on the property, tax sale and sealed bids to be opened on January 18th.

Mayor Hall declared the motion carried by the following vote: YEA Commissioner Closson, YEA Commissioner Cox, YEA Commissioner Graven, YEA Commissioner Phipps, YEA Mayor Hall.

Mayor Hall seconded by Commissioner Phipps moved to adopt Resolution No. 2021-3166, amending the City's Flexible Spending Account (FSA) Plan to reflect the IRS Announcement 2021-7, allowing personal protection equipment to be reimbursed.

CITY OF MATTOON, ILLINOIS

RESOLUTION NO. 2021-3166

A RESOLUTION AMENDING THE CITY OF MATTOON FLEXIBLE SPENDING ACCOUNT PLAN TO REFLECT THE ADDITION OF IRS ANNOUNCEMENT 2021-7, ALLOWING PERSONAL PROTECTION EQUIPMENT TO BE REIMBURSED

WHEREAS, the City of Mattoon has an employee benefit of a 125 Cafeteria Flexible Spending Account Plan; and

WHEREAS, the IRS has made an announcement allowing for the reimbursement of Personal Protective Equipment (PPE) through Flexible Spending Accounts; and

WHEREAS, the City of Mattoon wishes to formally amend its FSA to include the IRS Announcement 2021-7 modification.

NOW, THEREFORE, BE IT RESOLVED BY THE CITY COUNCIL FOR THE CITY OF MATTOON, COLES COUNTY, ILLINOIS as follows:

Section 1. The Council hereby approves the amendment to the City of Mattoon Flexible Spending Account Plan to include IRS Announcement 2021-7.

Section 2. The Council hereby authorizes the Mayor to sign all documents necessary to make the amendments.

Upon motion by Mayor Hall, seconded by Commissioner Phipps, adopted this 7th day of December, 2021 by a roll call vote, as follows:

AYES (Names): Commissioner Closson, Commissioner Cox,
Commissioner Graven, Commissioner Phipps, Mayor Hall

NAYS (Names): None

ABSENT: (Names): None

Approved this 7th day of December, 2021.

/s/Rick Hall
Rick Hall, Mayor
City of Mattoon, Coles County, Illinois

ATTEST:

APPROVED AS TO FORM:

/s/Susan J. O'Brien
Susan J. O'Brien, City Clerk

/s/Daniel C. Jones
Daniel C. Jones, City Attorney

Recorded in the Municipality's Records on December 7, 2021.

Mayor Hall opened the floor for comments. Mayor Hall noted the modification of items due to the IRS Announcement 2021-7.

Mayor Hall declared the motion carried by the following vote: YEA Commissioner Closson, YEA Commissioner Cox, YEA Commissioner Graven, YEA Commissioner Phipps, YEA Mayor Hall.

Mayor Hall seconded by Commissioner Graven moved to adopt Resolution No. 2021-3167, approving the continuance of a Local State of Emergency due to the Coronavirus (COVID – 19).

CITY OF MATTOON, ILLINOIS

RESOLUTION NO. 2021-3167

DECLARATION OF LOCAL STATE OF EMERGENCY

Pursuant to the authority vested in the office of Mayor by the Illinois Municipal Code Section 5/11-1-6, the Illinois Emergency Management Agency Act Section 3305/11 and Ordinance No. 2020-5430 of the City of Mattoon, I, Rick Hall, Mayor of the City of Mattoon do hereby declare that a Local State of Emergency exists as of this date, December 07, 2021, and shall continue until such time as provided in Ordinance No. 2020-5430.

WHEREAS, on January 30, 2020, the World Health Organization declared the outbreak of COVID-19 to be a public health emergency of international concern and on March 11, 2020 declared a worldwide pandemic; and

WHEREAS, on January 31, 2020, the U.S. Health and Human Services Secretary declared a public health emergency for the United States; and

WHEREAS, the Governor of the State of Illinois has issued a disaster proclamation on March 9, 2020 due to the impact of the COVID-19 virus and has activated the State Emergency Operations Center; and

WHEREAS, the State Emergency Management Agency has declared a public health emergency due to the impact of the COVID-19 virus; and

WHEREAS, the City Administration has coordinated its response with other Coles County governmental entities.

The nature of the emergency is related to the COVID-19 virus which is causing or anticipated to cause widespread impacts on the health of members of the community.

During the existence of the Local State of Emergency, the Mayor shall execute such authority as provided under the Illinois Municipal Code, the Illinois Emergency Management Agency Act and Ordinance No. 2020-5430.

This Declaration of Local State of Emergency shall be filed with the City Clerk as soon as practicable.

I, Rick Hall, whose name is signed to this instrument, being first duly sworn, signed and executed the instrument as the Declaration of Local State of Emergency, and that I signed willingly, and that I executed it as my free and voluntary act for the purposes therein expressed.

/s/Rick Hall
Rick Hall, Mayor
City of Mattoon, Coles County, Illinois

Mayor Hall noted the resolution each meeting.

Mayor Hall declared the motion carried by the following vote: YEA Commissioner Closson, YEA Commissioner Cox, YEA Commissioner Graven, YEA Commissioner Phipps, YEA Mayor Hall.

DEPARTMENT REPORTS:

CITY ADMINISTRATOR/COMMUNITY DEVELOPMENT noted preparation of agenda items, reviewing other properties for surplus, nuisance calls with Police Department, upcoming TIF and RLF meeting. Mayor Hall opened the floor for questions with no response.

CITY ATTORNEY noted business as usual with nuisance properties including a hearing resulting in the Judge to rule on the Quakenbush property and provide a written decision. Mayor Hall opened the floor for questions with no response.

CITY CLERK noted the Office was processing renewal of liquor licenses, birth/death certificate, Dodge Grove Cemetery requests, and processing the Employee Health Insurance Election Forms/Updates. Mayor Hall opened the floor for questions with response.

FINANCE noted the final installation of property taxes in the amount of \$634,000 with total collections of approximately 99.625% of what was levied; distributed the Revenue Tracking for November, allocation per capita based on new census, unrestricted cash including American Rescue Plan funds. Commissioner Graven noted the funds were half of all the money. Director & Treasurer Wright noted the second half would be received in September 2022.

PUBLIC WORKS congratulated the Downtown business owners for a great Downtown Celebration. Commissioner Cox remarked that the Streetscaping project looked phenomenal with two blocks to go.

FIRE thanked the Council for the new prospective employees; reported on the calls for service, inspections and follow-ups, training, walkthrough of Hilton Garden Inn, ARP and EMS training, and preparation of council agenda items. Mayor Hall opened the floor for questions with no response.

POLICE congratulated the new firefighters, announced the Shop with a Cop event, thanked the businesses for their donations and reported on the calls for service. Mayor Hall opened the floor for questions with no response.

ARTS AND TOURISM Commissioner Cox reported for Director Burgett, who was attending a conference, with a Lightworks update and Hotel/Motel revenues of 98% of pre-pandemic level. Mayor Hall opened the floor for questions with no response.

COMMENTS BY THE COUNCIL

Council welcomed the new firefighters. Commissioner Closson noted a meeting with Director Barber to discuss capital improvements for next year and with Administrator Gill to discuss the Lakes position job description and advertisement. Commissioner Cox thanked the Mayor for Pearl Harbor Remembrance Day acknowledgement and stated best wishes to the Christian School. Commissioner Graven announced the model train as operational in the Coles County Historical Society Museum, complemented the successful Downtown Celebration and wished the Christian School success. Commissioner Phipps reiterated Director Barber's comments on the Downtown Celebration, thanked Mr. Nichols for the audit, and noted the next Public Works meeting would discuss the upcoming capital budget. Mayor Hall updated Council on the sports complex and professional grant writer for the City.

Mayor Hall seconded by Commissioner Cox moved to recess to closed session at 7:33 p.m. pursuant to the Illinois Open Meetings Act for the purpose of the discussion of the appointment, compensation, discipline, performance, or dismissal of specific employees of the City or legal counsel for the City. (5ILCS 120 (2)(C)(1)); collective negotiating matters between the City of Mattoon and its employees or their representatives, or deliberations concerning salary schedules for one or more classes of employees (5ILCS 120 (2)(C)(2)); litigation which is affecting the City and an action is probable or imminent (5ILCS 120 (2)(C)(11)).

Mayor Hall declared the motion carried by the following vote: YEA Commissioner Closson, YEA Commissioner Cox, YEA Commissioner Graven, YEA Commissioner Phipps, YEA Mayor Hall.

Council reconvened at 8:50 p.m.

Commissioner Cox seconded by Commissioner Phipps moved to adjourn at 8:50 p.m.

Mayor Hall declared the motion carried by the following vote: YEA Commissioner Closson, YEA Commissioner Cox, NAY Commissioner Graven, YEA Commissioner Phipps, YEA Mayor Hall.

/s/Susan J. O'Brien
City Clerk

BILLS & PAYROLL:

BILLS & PAYROLL BEGIN ON THE NEXT PAGE.

CITY OF MATTOON
 PAYROLL 12/10/2021
 11/20/2021-12/3/2021

	G/L ACCOUNT	ACCOUNT NAME	AMOUNT
CITY COUNCIL	110 5110-111	SALARIES OF REG EMPLOYEES	\$ 502.17
CITY CLERK	110 5120-111	SALARIES OF REG EMPLOYEES	\$ 2,996.98
	110 5120-114	COMPENSATED ABSENCES	\$ 757.74
CITY ADMINISTRATOR	110 5130-111	SALARIES OF REG EMPLOYEES	\$ 1,340.36
	110 5130-114	COMPENSATED ABSENCES	\$ 148.92
FINANCIAL ADMINISTRATION	110 5150-111	SALARIES OF REG EMPLOYEES	\$ 1,565.63
	110 5150-114	COMPENSATED ABSENCES	\$ 242.50
COMPUTER INFO SYSTEMS	110 5170-111	SALARIES OF REG EMPLOYEES	\$ 2,538.46
POLICE ADMINISTRATION	110 5211-111	SALARIES OF REG EMPLOYEES	\$ 14,195.36
CRIMINAL INVESTIGATION	110 5212-111	SALARIES OF REG EMPLOYEES	\$ 11,260.18
	110 5212-113	OVERTIME	\$ 326.71
PATROL	110 5213-111	SALARIES OF REG EMPLOYEES	\$ 74,593.94
	110 5213-113	OVERTIME	\$ 3,271.29
	110 5213-114	COMPENSATED ABSENCES	\$ 24.32
K-9 SERVICE	110 5214-111	SALARIES OF REG EMPLOYEES	\$ 5,317.46
SCHOOL RESOURCE PROGRAM	110 5227-111	SALARIES OF REG EMPLOYEES	\$ 6,489.32
FIRE PROTECTION ADMIN	110 5241-111	SALARIES OF REG EMPLOYEES	\$ 58,207.75
	110 5241-113	OVERTIME	\$ 12,694.09
	110 5241-114	COMPENSATED ABSENCES	\$ 15,691.24
	110 5261-111	SALARIES OF REG EMPLOYEES	\$ 2,538.34
	110 5261-114	COMPENSATED ABSENCES	\$ 13.33
PUBLIC WORKS ADMIN	110 5310-111	SALARIES OF REG EMPLOYEES	\$ 5,023.56
	110 5310-114	COMPENSATED ABSENCES	\$ 227.16
STREETS	110 5320-111	SALARIES OF REG EMPLOYEES	\$ 8,539.32
	110 5320-113	OVERTIME	\$ 434.61
	110 5320-114	COMPENSATED ABSENCES	\$ 1,873.41
CUSTODIAL SERVICES	110 5381-111	SALARIES OF REG EMPLOYEES	\$ 765.58
	110 5381-114	COMPENSATED ABSENCES	\$ 1,545.62
PARK ADMINISTRATION	110 5511-111	SALARIES OF REG EMPLOYEES	\$ 9,389.02
	110 5511-113	OVERTIME	\$ 2,485.42
	110 5511-114	COMPENSATED ABSENCES	\$ 329.55
LAKE MATTOON	110 5512-111	SALARIES OF REG EMPLOYEES	\$ 3,873.36
	110 5512-114	COMPENSATED ABSENCES	\$ 25,250.81
CEMETERY	110 5570-111	SALARIES OF REG EMPLOYEES	\$ 2,816.10
	110 5570-113	OVERTIME	\$ 831.11
		*** FUND 110 TOTALS ***	\$ 278,100.72
HOTEL TAX ADMINISTRATION	122 5653-111	SALARIES OF REG EMPLOYEES	\$ 3,045.84
		*** FUND 122 TOTALS ***	\$ 3,045.84

CITY OF MATTOON
 PAYROLL 12/10/2021
 11/20/2021-12/3/2021

WATER TREATMENT PLANT	211 5353-111	SALARIES OF REG EMPLOYEES	\$ 14,202.28
	211 5353-113	OVERTIME	\$ 3,167.98
	211 5353-114	COMPENSATED ABSENCES	\$ 1,719.23
WATER DISTRIBUTION	211 5354-111	SALARIES OF REG EMPLOYEES	\$ 8,288.14
	211 5354-113	OVERTIME	\$ 818.38
	211 5354-114	COMPENSATED ABSENCES	\$ 1,818.21
ACCOUNTING & COLLECTION	211 5355-111	SALARIES OF REG EMPLOYEES	\$ 5,297.97
	211 5355-114	COMPENSATED ABSENCES	\$ 1,247.56
ADMINISTRATIVE & GENERAL	211 5356-111	SALARIES OF REG EMPLOYEES	\$ 8,408.01
	211 5356-114	COMPENSATED ABSENCES	\$ 504.91
		*** FUND 211 TOTALS ***	\$ 45,472.67
SANITARY SEWER MTCE & CLEAN	212 5342-111	SALARIES OF REG EMPLOYEES	\$ 8,288.14
	212 5342-113	OVERTIME	\$ 624.21
	212 5342-114	COMPENSATED ABSENCES	\$ 1,818.21
WASTEWATER TREATMENT PLANT	212 5344-111	SALARIES OF REG EMPLOYEES	\$ 13,864.64
	212 5344-114	COMPENSATED ABSENCES	\$ 503.50
ACCOUNTING & COLLECTION	212 5345-111	SALARIES OF REG EMPLOYEES	\$ 5,297.97
	212 5345-114	COMPENSATED ABSENCES	\$ 1,247.56
ADMINISTRATIVE & GENERAL	212 5346-111	SALARIES OF REG EMPLOYEES	\$ 8,408.00
	212 5346-114	COMPENSATED ABSENCES	\$ 504.92
		*** FUND 212 TOTALS ***	\$ 40,557.15
		*** GRAND TOTALS ***	\$ 367,176.38

CITY OF MATTOON
PAYROLL 12/10/2021
11/20/2021-12/3/2021

*** PAY CODE TOTALS ***

PAY CODE	NO OF TIMES	HOURS	AMOUNT
SALARY PAY	128	9,831.04	\$ 280,976.45
VACATION PAY	24	298	\$ 9,537.69
HOLIDAY PAY-REGULAR	31	135.6	\$ 3,427.39
OVERTIME PAY	25	537.5	\$ 21,124.28
VACATION PAY	7	312	\$ 8,129.20
COMP PAID	4	117.5	\$ 3,516.18
SICK PAY-AFSCME	7	139.5	\$ 3,924.92
SICK-FD UNION	4	202	\$ 5,035.01
COMP EARNED	3	36	\$ -
CAPTAIN PAY	3	96	\$ 96.00
SICK PAY OUT	1	446.98	\$ 13,389.73
VACATION PAY OUT	2	400.89	\$ 11,943.90
BACK PAY	1		\$ 81.09
BACK PAY-OT	1		\$ 6.08
SHIFT PAY	6	286	\$ 223.08
SHIFT PAY	4	100	\$ 68.00
HOLIDAY PAY-OT	2	48	\$ 1,985.83
REGULAR PAY	6	117	\$ 2,087.00
STRAIGHT OT POLICE	3	44.5	\$ 1,543.69
SICK-NON UNION	1	2.25	\$ 80.86

VENDOR SET: 01 CITY OF MATTOON

BANK: APBNK

FUND : 110 GENERAL FUND

DEPARTMENT: N/A NON-DEPARTMENTAL

INVOICE DATE RANGE: 1/01/1998 THRU 99/99/9999

PAY DATE RANGE: 12/08/2021 THRU 12/21/2021

BUDGET TO USE: CB-CURRENT BUDGET

VENDOR	NAME	ITEM #	G/L ACCOUNT	NAME	DESCRIPTION	CHECK #	AMOUNT		
01-003328	DOEHRING, WINDERS & CO	I-202112150812	110 1141-007	DUE FROM LIBR:	AUDITING SERVICES	150791	900.00		
01-003328	DOEHRING, WINDERS & CO	I-202112150812	110 1141-002	DUE FROM REV.:	AUDITING SERVICES	150791	1,350.00		
						VENDOR 01-003328 TOTALS	2,250.00		
01-017200	FIRE PENSION FUND	I-202112100737	110 2172-001	DUE TO FIREFI:	DECEMBER PPRT	150715	23,388.11		
						VENDOR 01-017200 TOTALS	23,388.11		
01-030100	MATTOON PUBLIC LIBRARY	I-202112100735	110 2172-000	DUE TO LIBRAR:	DECEMBER PPRT	150716	3,792.67		
						VENDOR 01-030100 TOTALS	3,792.67		
01-038700	POLICE PENSION FUND	I-202112100736	110 2172-002	DUE TO POLICE:	DECEMBER PPRT	150718	23,388.12		
						VENDOR 01-038700 TOTALS	23,388.12		
						DEPARTMENT	NON-DEPARTMENTAL	TOTAL:	52,818.90
01-001679	CHRIS OVERTON EXCAVATI	I-202112160868	110 5110-827	VGT ALLOCATIO:	DEMO 3217 MOULTRIE	150746	8,950.00		
						VENDOR 01-001679 TOTALS	8,950.00		
01-001886	RICK HALL	I-DEC2021-CELLRH	110 5110-533	CELLULAR PHON:	CELL PHONE	000281	50.00		
						VENDOR 01-001886 TOTALS	50.00		
01-003024	DAVID COX	I-DEC2021-CELLDC	110 5110-533	CELLULAR PHON:	CELL PHONE	000284	50.00		
						VENDOR 01-003024 TOTALS	50.00		
01-004232	DAVID M PHIPPS	I-DEC2021-CELLDP	110 5110-533	CELLULAR PHON:	CELL PHONE	000286	50.00		
						VENDOR 01-004232 TOTALS	50.00		
01-004233	JAMES E CLOSSON	I-DEC2021-CELLJC	110 5110-533	CELLULAR PHON:	CELL PHONE REIMBURSE	150773	50.00		
						VENDOR 01-004233 TOTALS	50.00		

VENDOR SET: 01 CITY OF MATTOON

BANK: APBNK

FUND : 110 GENERAL FUND

DEPARTMENT: 110 CITY COUNCIL

INVOICE DATE RANGE: 1/01/1998 THRU 99/99/9999

PAY DATE RANGE: 12/08/2021 THRU 12/21/2021

BUDGET TO USE: CB-CURRENT BUDGET

VENDOR	NAME	ITEM #	G/L ACCOUNT	NAME	DESCRIPTION	CHECK #	AMOUNT
01-009800	COLES CO CLERK & RECOR	I-4082509	110 5110-827	VGT ALLOCATIO:	DEMO 3217 MOULTRIE	150778	60.00
						VENDOR 01-009800 TOTALS	60.00
01-023800	CONSOLIDATED COMMUNICA	I-202112100763	110 5110-532	TELEPHONE	: 234-4633	003939	59.77
						VENDOR 01-023800 TOTALS	59.77
DEPARTMENT 110 CITY COUNCIL						TOTAL:	9,269.77
01-003762	XEROX FINANCIAL SERVIC	I-2969997	110 5120-814	PRINT/COPY MA:	LEASE & USE	150880	601.40
						VENDOR 01-003762 TOTALS	601.40
01-009800	COLES CO CLERK & RECOR	I-4082363	110 5120-519	OTHER PROFESS:	RECORD LIENS	150778	120.00
01-009800	COLES CO CLERK & RECOR	I-4082406	110 5120-519	OTHER PROFESS:	RECORD DEED	150778	66.00
						VENDOR 01-009800 TOTALS	186.00
01-010900	D TO Z SPORTS	I-28382	110 5120-519	OTHER PROFESS:	RETIREMENT CLOCKS	150785	120.00
						VENDOR 01-010900 TOTALS	120.00
01-023800	CONSOLIDATED COMMUNICA	I-202112100759	110 5120-532	TELEPHONE	: 235-5654	003936	284.68
						VENDOR 01-023800 TOTALS	284.68
DEPARTMENT 120 CITY CLERK						TOTAL:	1,192.08
01-018700	KYLE GILL	I-DEC2021-CELLKG	110 5130-565	CELLULAR PHON:	CELL PHONE	000287	100.00
						VENDOR 01-018700 TOTALS	100.00
DEPARTMENT 130 CITY ADMINISTRATOR						TOTAL:	100.00
01-000720	CARDMEMBER SERVICES	I-202112160828	110 5150-516	TECHNOLOGY SU:	TAX & ACCOUNTING PRO	150768	141.66
						VENDOR 01-000720 TOTALS	141.66

VENDOR SET: 01 CITY OF MATTOON

BANK: APBNK

FUND : 110 GENERAL FUND

DEPARTMENT: 150 FINANCIAL ADMINISTRATION

INVOICE DATE RANGE: 1/01/1998 THRU 99/99/9999

PAY DATE RANGE: 12/08/2021 THRU 12/21/2021

BUDGET TO USE: CB-CURRENT BUDGET

VENDOR	NAME	ITEM #	G/L ACCOUNT	NAME	DESCRIPTION	CHECK #	AMOUNT
01-001663	ADVANCED DIGITAL SOLUT	I-IN35983	110 5150-814	PRINT/COPY MA:	XEROX 3330	150751	11.83
					VENDOR 01-001663	TOTALS	11.83
01-002931	BETH WRIGHT	I-DEC2021-CELLBW	110 5150-532	TELEPHONE :	CELL PHONE	150878	100.00
					VENDOR 01-002931	TOTALS	100.00
01-003328	DOEHRING, WINDERS & CO	I-202112150812	110 5150-513	AUDITING & AC:	AUDITING SERVICES	150791	4,050.00
					VENDOR 01-003328	TOTALS	4,050.00
01-003527	INB	I-202112160821	110 5150-811	BANK SERVICE :	EPAY FEES 11/2021	150815	13.87
					VENDOR 01-003527	TOTALS	13.87
01-003880	NCR PAYMENT SOLUTIONS	I-202112150797	110 5150-811	BANK SERVICE :	EPAY FEES 11/2021	003979	12.88
					VENDOR 01-003880	TOTALS	12.88
01-004290	TYLER BUSINESS FORMS	I-65749	110 5150-311	OFFICE SUPPLI:	TAX FORMS	150869	39.74
					VENDOR 01-004290	TOTALS	39.74
01-023800	CONSOLIDATED COMMUNICA	I-202112100759	110 5150-532	TELEPHONE :	235-5654	003936	59.79
					VENDOR 01-023800	TOTALS	59.79
						DEPARTMENT 150 FINANCIAL ADMINISTRATION TOTAL:	4,429.77
01-001286	ANCEL GLINK, P.C.	I-82914	110 5160-519	OTHER PROFESS:	LEGAL SERVICES	150755	10.14
					VENDOR 01-001286	TOTALS	10.14
01-002401	SMITHAMUNDSEN	I-664565	110 5160-515	LABOR RELATIO:	LEGAL SERVICES	150858	2,835.00
					VENDOR 01-002401	TOTALS	2,835.00
						DEPARTMENT 160 LEGAL SERVICES	TOTAL: 2,845.14

VENDOR SET: 01 CITY OF MATTOON

BANK: APBNK

FUND : 110 GENERAL FUND

DEPARTMENT: 170 COMPUTER INFO SYSTEMS

INVOICE DATE RANGE: 1/01/1998 THRU 99/99/9999

PAY DATE RANGE: 12/08/2021 THRU 12/21/2021

BUDGET TO USE: CB-CURRENT BUDGET

VENDOR	NAME	ITEM #	G/L ACCOUNT	NAME	DESCRIPTION	CHECK #	AMOUNT
01-000720	CARDMEMBER SERVICES	I-202112160828	110 5170-325	SOFTWARE	: LAST PASS	150768	256.00
						VENDOR 01-000720 TOTALS	256.00
						DEPARTMENT 170 COMPUTER INFO SYSTEMS TOTAL:	256.00
01-000151	INDUSTRIAL ORGANIZATIO	I-C51796A	110 5211-579	MISC OTHER PU:	PD EXAMS	150816	4,750.00
01-000151	INDUSTRIAL ORGANIZATIO	I-C51835A	110 5211-519	OTHER PROFESS:	PD RECRUITMENT & TES	150816	351.21
						VENDOR 01-000151 TOTALS	5,101.21
01-000720	CARDMEMBER SERVICES	I-202112160828	110 5211-825	SEIZURES/FORF:	MCFARLAND STEEL	150768	50.00
01-000720	CARDMEMBER SERVICES	I-202112160828	110 5211-825	SEIZURES/FORF:	LITTLE CAESARS	150768	18.43
01-000720	CARDMEMBER SERVICES	I-202112160828	110 5211-319	MISCELLANEOUS:	WALMART	150768	50.56
01-000720	CARDMEMBER SERVICES	I-202112160828	110 5211-825	SEIZURES/FORF:	VILLA	150768	43.70
						VENDOR 01-000720 TOTALS	162.69
01-001663	ADVANCED DIGITAL SOLUT	I-IN35773	110 5211-814	PRINT/COPY MA:	XEROX 6600, HP LJ EN	150751	21.36
						VENDOR 01-001663 TOTALS	21.36
01-003762	XEROX FINANCIAL SERVIC	I-2969997	110 5211-814	PRINT/COPY MA:	LEASE & USE	150880	240.91
						VENDOR 01-003762 TOTALS	240.91
01-003811	VERIZON WIRELESS-VSAT	I-21396805-48778664	110 5211-579	MISC OTHER PU:	VERIZON WIRELESS-VSA	150875	50.00
						VENDOR 01-003811 TOTALS	50.00
01-004073	SILEC	I-202112150801	110 5211-562	TRAVEL & TRAI:	CRIMINAL JUSTICE SUM	150857	170.00
						VENDOR 01-004073 TOTALS	170.00
01-004307	ZERO9 HOLSTERS	I-3322	110 5211-825	SEIZURES/FORF:	HANDCUFF, TASER,BODY	150882	7,294.75
						VENDOR 01-004307 TOTALS	7,294.75

VENDOR SET: 01 CITY OF MATTOON

BANK: APBNK

FUND : 110 GENERAL FUND

DEPARTMENT: 211 POLICE ADMINISTRATION

INVOICE DATE RANGE: 1/01/1998 THRU 99/99/9999

PAY DATE RANGE: 12/08/2021 THRU 12/21/2021

BUDGET TO USE: CB-CURRENT BUDGET

VENDOR	NAME	ITEM #	G/L ACCOUNT	NAME	DESCRIPTION	CHECK #	AMOUNT
01-023800	CONSOLIDATED COMMUNICA	I-202112100757	110 5211-532	TELEPHONE	: 235-2677	003934	1,750.00
VENDOR 01-023800 TOTALS							1,750.00
01-030056	LAKE LAND FLORALS	I-013651	110 5211-319	MISCELLANEOUS:	EASTON FLOWERS	150824	66.99
VENDOR 01-030056 TOTALS							66.99
01-037800	RAY O'HERRON CO	I-2161109-IN	110 5211-315	UNIFORMS & CL:	NAME BAR	150851	18.11
01-037800	RAY O'HERRON CO	I-2161113-IN	110 5211-315	UNIFORMS & CL:	BADGES	150851	539.99
VENDOR 01-037800 TOTALS							558.10
01-038331	PF PETTIBONE & CO	I-181440	110 5211-550	PRINTING & BI:	WARNING STICKERS	150849	178.90
VENDOR 01-038331 TOTALS							178.90
DEPARTMENT 211 POLICE ADMINISTRATION						TOTAL:	15,594.91
01-000720	CARDMEMBER SERVICES	I-202112160828	110 5212-319	MISCELLANEOUS:	RIMAGE	150768	504.43
VENDOR 01-000720 TOTALS							504.43
01-004023	TRANSUNION RISK AND AL	I-4800121-202111-1	110 5212-579	MISC OTHER PU:	11/2021 SEARCHES	150867	110.00
VENDOR 01-004023 TOTALS							110.00
DEPARTMENT 212 CRIMINAL INVESTIGATION						TOTAL:	614.43
01-002666	COLES CO CRISIS RESPON	I-202112150804	110 5213-579	MISC OTHER PU:	MRAP PAINTING	150779	500.00
VENDOR 01-002666 TOTALS							500.00
DEPARTMENT 213 PATROL						TOTAL:	500.00
01-001582	AUTO, TRUCK AND FARM R	I-73620	110 5223-434	REPAIR OF VEH:	SQUAD SERVICE	150756	51.02

VENDOR SET: 01 CITY OF MATTOON

BANK: APBNK

FUND : 110 GENERAL FUND

DEPARTMENT: 223 AUTOMOTIVE SERVICES

INVOICE DATE RANGE: 1/01/1998 THRU 99/99/9999

PAY DATE RANGE: 12/08/2021 THRU 12/21/2021

BUDGET TO USE: CB-CURRENT BUDGET

VENDOR	NAME	ITEM #	G/L ACCOUNT	NAME	DESCRIPTION	CHECK #	AMOUNT
01-001582	AUTO, TRUCK AND FARM R	I-73621	110 5223-434	REPAIR OF VEH:	SQUAD REPAIRS	150756	391.91
01-001582	AUTO, TRUCK AND FARM R	I-73625	110 5223-434	REPAIR OF VEH:	SQUAD SERVICE	150756	51.02
01-001582	AUTO, TRUCK AND FARM R	I-73664	110 5223-434	REPAIR OF VEH:	SQUAD SERVICE	150756	65.21
						VENDOR 01-001582 TOTALS	559.16
01-019020	GLOBAL TECHNICAL SYSTE	I-116001049-1	110 5223-318	VEHICLE PARTS:	GLOBAL TECHNICAL SYS	150801	15.00
						VENDOR 01-019020 TOTALS	15.00
						DEPARTMENT 223 AUTOMOTIVE SERVICES TOTAL:	574.16
01-002194	IL POWER MARKETING DBA	I-1461321111	110 5224-321	UTILITIES	: 1700 WABASH	150813	2,106.97
01-002194	IL POWER MARKETING DBA	I-1461321111	110 5224-321	UTILITIES	: 620 S 12TH	150813	20.49
						VENDOR 01-002194 TOTALS	2,127.46
01-002250	COMMERCIAL REFRIGERATI	I-47562	110 5224-439	OTHER REPAIR :	BOILER REPAIRS	150782	914.76
						VENDOR 01-002250 TOTALS	914.76
01-009000	COMMERCIAL ELECTRIC, I	I-20340901	110 5224-439	OTHER REPAIR :	REPLACE EMERGENCY LI	150781	195.07
						VENDOR 01-009000 TOTALS	195.07
01-030000	KULL LUMBER CO	I-202112150808	110 5224-316	TOOLS & EQUIP:	YARD BAGS, LEAF SCOO	150821	2.96
						VENDOR 01-030000 TOTALS	2.96
01-033800	MATTOON WATER DEPT	I-202112100786	110 5224-321	UTILITIES	: 1710 WABASH	003961	174.57
01-033800	MATTOON WATER DEPT	I-202112100787	110 5224-321	UTILITIES	: 221 S 17TH	003962	43.42
						VENDOR 01-033800 TOTALS	217.99
						DEPARTMENT 224 POLICE BUILDINGS TOTAL:	3,458.24
01-000430	AEC FIRE-SAFETY & SECU	I-260149	110 5241-315	UNIFORMS & CL:	BOOTS	150752	686.81

VENDOR SET: 01 CITY OF MATTOON

BANK: APBNK

FUND : 110 GENERAL FUND

DEPARTMENT: 241 FIRE PROTECTION ADMIN.

INVOICE DATE RANGE: 1/01/1998 THRU 99/99/9999

PAY DATE RANGE: 12/08/2021 THRU 12/21/2021

BUDGET TO USE: CB-CURRENT BUDGET

VENDOR	NAME	ITEM #	G/L ACCOUNT	NAME	DESCRIPTION	CHECK #	AMOUNT
01-000430	AEC FIRE-SAFETY & SECU	I-260211	110 5241-315	UNIFORMS & CL:	SPECTACLE KIT	150752	652.91
						VENDOR 01-000430 TOTALS	1,339.72
01-000720	CARDMEMBER SERVICES	I-202112160828	110 5241-315	UNIFORMS & CL:	WALMART	150768	39.62
01-000720	CARDMEMBER SERVICES	I-202112160828	110 5241-315	UNIFORMS & CL:	WPSG	150768	641.50
01-000720	CARDMEMBER SERVICES	I-202112160828	110 5241-315	UNIFORMS & CL:	FIREPENNY	150768	97.48-
01-000720	CARDMEMBER SERVICES	I-202112160828	110 5241-315	UNIFORMS & CL:	WPSG	150768	156.38-
						VENDOR 01-000720 TOTALS	427.26
01-001398	IL FIRE CHIEFS ASSOCIA	I-3355	110 5241-571	DUES & MEMBER:	MEMBERSHIP	150812	450.00
						VENDOR 01-001398 TOTALS	450.00
01-001663	ADVANCED DIGITAL SOLUT	I-IN35859	110 5241-814	PRINT/COPY MA:	XEROX 3345	150751	9.35
01-001663	ADVANCED DIGITAL SOLUT	I-IN35881	110 5241-814	PRINT/COPY MA:	XEROX 3345	150751	18.00
						VENDOR 01-001663 TOTALS	27.35
01-002194	IL POWER MARKETING DBA	I-1461321111	110 5241-321	UTILITIES	: 2700 MARSHALL	150813	101.50
01-002194	IL POWER MARKETING DBA	I-1461321111	110 5241-321	UTILITIES	: 2700 MARSHALL STA 3	150813	3.22
01-002194	IL POWER MARKETING DBA	I-1461321111	110 5241-321	UTILITIES	: 1801 PRAIRIE	150813	45.71
01-002194	IL POWER MARKETING DBA	I-1461321111	110 5241-321	UTILITIES	: 1801 PRAIRIE	150813	1.37
						VENDOR 01-002194 TOTALS	151.80
01-002401	SMITHAMUNDSEN	I-665717	110 5241-515	LABOR RELATIO:	LEGAL SERVICES	150858	8,310.00
						VENDOR 01-002401 TOTALS	8,310.00
01-002940	BANNER FIRE EQUIPMENT	I-01S8160	110 5241-434	REPAIR OF VEH:	ENGINE 21 REPAIRS	150757	1,146.25
01-002940	BANNER FIRE EQUIPMENT	I-01S8256	110 5241-434	REPAIR OF VEH:	ENGINE 21 REPAIRS	150757	1,365.00
						VENDOR 01-002940 TOTALS	2,511.25
01-002958	BATTERY SPECIALISTS, I	I-185077	110 5241-316	TOOLS & EQUIP:	FLASHLIGHTS	150759	179.70
						VENDOR 01-002958 TOTALS	179.70

VENDOR SET: 01 CITY OF MATTOON

BANK: APBNK

FUND : 110 GENERAL FUND

DEPARTMENT: 241 FIRE PROTECTION ADMIN.

INVOICE DATE RANGE: 1/01/1998 THRU 99/99/9999

PAY DATE RANGE: 12/08/2021 THRU 12/21/2021

BUDGET TO USE: CB-CURRENT BUDGET

VENDOR	NAME	ITEM #	G/L ACCOUNT	NAME	DESCRIPTION	CHECK #	AMOUNT
01-002981	BIO-TRON, INC.	I-40653	110 5241-433	REPAIR OF MAC:	PREVENTATIVE MNTCE	150760	450.00
					VENDOR 01-002981 TOTALS		450.00
01-003056	CAMPION, BARROW & ASSO	I-030422	110 5241-519	OTHER PROFESS:	FIRE SERVICES TESTIN	150767	880.00
					VENDOR 01-003056 TOTALS		880.00
01-003320	WEX BANK	I-76409461	110 5241-326	FUEL	: FUEL	150876	37.07
					VENDOR 01-003320 TOTALS		37.07
01-003762	XEROX FINANCIAL SERVIC	I-2981991	110 5241-814	PRINT/COPY MA:	LEASE PAYMENT	150881	34.23
					VENDOR 01-003762 TOTALS		34.23
01-003943	FESSI	I-E118204A	110 5241-433	REPAIR OF MAC:	EXTINGUISHER MNTCE	150795	303.75
01-003943	FESSI	I-E118213	110 5241-433	REPAIR OF MAC:	EXINGUISHER MNTCE	150795	63.45
					VENDOR 01-003943 TOTALS		367.20
01-007890	DUST & SON OF COLES CO	I-S4-381421	110 5241-319	MISCELLANEOUS:	OIL DRY	150794	78.28
					VENDOR 01-007890 TOTALS		78.28
01-010900	D TO Z SPORTS	I-28337	110 5241-315	UNIFORMS & CL:	NAME PLATES	150785	24.00
					VENDOR 01-010900 TOTALS		24.00
01-011875	DENNING AUTOMOTIVE	I-202112150816	110 5241-434	REPAIR OF VEH:	IMPALA REPAIRS	150788	100.26
					VENDOR 01-011875 TOTALS		100.26
01-012970	DON BAKER'S PEST CONTR	I-18210	110 5241-579	MISC OTHER PU:	PEST CONTROL	150792	75.00
01-012970	DON BAKER'S PEST CONTR	I-18219	110 5241-579	MISC OTHER PU:	PEST CONTROL	150792	75.00
01-012970	DON BAKER'S PEST CONTR	I-18390	110 5241-579	MISC OTHER PU:	PEST CONTROL	150792	75.00
01-012970	DON BAKER'S PEST CONTR	I-18392	110 5241-579	MISC OTHER PU:	PEST CONTROL	150792	75.00
					VENDOR 01-012970 TOTALS		300.00

VENDOR SET: 01 CITY OF MATTOON

BANK: APBNK

FUND : 110 GENERAL FUND

DEPARTMENT: 241 FIRE PROTECTION ADMIN.

INVOICE DATE RANGE: 1/01/1998 THRU 99/99/9999

PAY DATE RANGE: 12/08/2021 THRU 12/21/2021

BUDGET TO USE: CB-CURRENT BUDGET

VENDOR	NAME	ITEM #	G/L ACCOUNT	NAME	DESCRIPTION	CHECK #	AMOUNT
01-018042	GALLS, LLC	I-019802482	110 5241-315	UNIFORMS & CL:	LEATHER FIRE BOOTS	150800	270.99
					VENDOR 01-018042	TOTALS	270.99
01-021515	JEFF HILLIGOSS	I-DEC2021-CELLJH	110 5241-533	CELLULAR PHON:	CELL PHONE	000288	100.00
					VENDOR 01-021515	TOTALS	100.00
01-023800	CONSOLIDATED COMMUNICA	I-202112100764	110 5241-532	TELEPHONE	: 235-0933	003940	205.66
01-023800	CONSOLIDATED COMMUNICA	I-202112100765	110 5241-532	TELEPHONE	: 234-2442	003941	266.30
					VENDOR 01-023800	TOTALS	471.96
01-025600	ILMO PRODUCTS COMPANY	I-01249723	110 5241-313	MEDICAL & SAF:	CYLINDER RENTAL	150814	53.70
					VENDOR 01-025600	TOTALS	53.70
01-031000	LORENZ SUPPLY CO.	I-565549	110 5241-312	CLEANING SUPP:	CUPS, TOWELS, CLEANERS	150828	155.78
					VENDOR 01-031000	TOTALS	155.78
01-033800	MATTOON WATER DEPT	I-202112100769	110 5241-321	UTILITIES	: 1801 PRAIRIE	003944	52.50
					VENDOR 01-033800	TOTALS	52.50
01-036080	MUNICIPAL EMERGENCY SE	I-IN1650827	110 5241-433	REPAIR OF MAC:	MUNICIPAL EMERGENCY	150841	159.57
					VENDOR 01-036080	TOTALS	159.57
01-040463	SARAH BUSH LINCOLN HEA	I-4520469	110 5241-568	PHYSICALS	: PREEMPLOYMENT PHYSIC	150854	1,021.40
					VENDOR 01-040463	TOTALS	1,021.40
01-043371	SPRINGFIELD ELECTRIC	I-S7084779.001	110 5241-434	REPAIR OF VEH:	PLUGS, CONNECTORS	150860	114.72
					VENDOR 01-043371	TOTALS	114.72

VENDOR SET: 01 CITY OF MATTOON

BANK: APBNK

FUND : 110 GENERAL FUND

DEPARTMENT: 241 FIRE PROTECTION ADMIN.

INVOICE DATE RANGE: 1/01/1998 THRU 99/99/9999

PAY DATE RANGE: 12/08/2021 THRU 12/21/2021

BUDGET TO USE: CB-CURRENT BUDGET

VENDOR	NAME	ITEM #	G/L ACCOUNT	NAME	DESCRIPTION	CHECK #	AMOUNT		
01-045198	UNIVERSITY OF IL PAYME	I-UFIW2432	110 5241-562	TRAVEL & TRAI:	FIRE OFFICER-OWEN	150872	1,000.00		
					VENDOR 01-045198	TOTALS	1,000.00		
						DEPARTMENT 241	FIRE PROTECTION ADMIN.	TOTAL:	19,068.74
01-001381	MATT FREDERICK	I-DEC2021-CELLMF	110 5261-533	CELLULAR PHON:	CELL PHONE	150796	50.00		
					VENDOR 01-001381	TOTALS	50.00		
01-003749	STEVE SUDKAMP	I-DEC2021-CELLSS	110 5261-533	CELLULAR PHON:	CELL P HONE	000285	50.00		
					VENDOR 01-003749	TOTALS	50.00		
01-003762	XEROX FINANCIAL SERVIC	I-2969997	110 5261-311	OFFICE SUPPLI:	LEASE & USE	150880	30.11		
					VENDOR 01-003762	TOTALS	30.11		
01-044200	KC SUMMERS BUICK	I-202112160818	110 5261-434	REPAIR OF VEH:	IMPALA & TAHOE REPAI	150820	1,463.21		
					VENDOR 01-044200	TOTALS	1,463.21		
						DEPARTMENT 261	COMMUNITY DEVELOPMENT	TOTAL:	1,593.32
01-002602	DEAN BARBER	I-DEC2021-CELLDB	110 5310-533	CELLULAR PHON:	CELL PHONE	000283	33.33		
					VENDOR 01-002602	TOTALS	33.33		
01-003488	SSC SERVICES, INC.	I-8300	110 5310-460	OTHER PROFESS:	JANITORIAL SERVICES	150861	66.00		
01-003488	SSC SERVICES, INC.	I-8304	110 5310-460	OTHER PROFESS:	JANITORIAL SERVICES	150861	66.00		
					VENDOR 01-003488	TOTALS	132.00		
01-003762	XEROX FINANCIAL SERVIC	I-2969997	110 5310-814	PRINT/COPY MA:	LEASE & USE	150880	72.35		
					VENDOR 01-003762	TOTALS	72.35		

VENDOR SET: 01 CITY OF MATTOON

BANK: APBNK

FUND : 110 GENERAL FUND

DEPARTMENT: 310 PUBLIC WORKS

INVOICE DATE RANGE: 1/01/1998 THRU 99/99/9999

PAY DATE RANGE: 12/08/2021 THRU 12/21/2021

BUDGET TO USE: CB-CURRENT BUDGET

VENDOR	NAME	ITEM #	G/L ACCOUNT	NAME	DESCRIPTION	CHECK #	AMOUNT
01-004298	WM CORPORATE SERVICES, I-	0005214-4072-7	110 5310-421	DISPOSAL SERV:	TRASH SERVICES	003983	218.26
01-004298	WM CORPORATE SERVICES, I-	0007309-2754-8	110 5310-421	DISPOSAL SERV:	TRASH SERVICES	003983	1,765.07
					VENDOR 01-004298 TOTALS		1,983.33
01-016000	JOHN DEERE FINANCIAL	I-202112160829	110 5310-319	MISCELLANEOUS:	JACKET,OVERALLS	150819	26.66
					VENDOR 01-016000 TOTALS		26.66
01-022300	HOWARD'S DISPOSAL, INC	I-1491831	110 5310-421	DISPOSAL SERV:	NOVEMBER SERVICES	150807	109.50
					VENDOR 01-022300 TOTALS		109.50
				DEPARTMENT 310	PUBLIC WORKS	TOTAL:	2,357.17
01-000755	ALTORFER	I-V2286802	110 5320-440	RENTALS	: EQUIPMENT RENTAL	150753	3,406.83
					VENDOR 01-000755 TOTALS		3,406.83
01-001213	DIESEL SPEED REPAIR, I	I-19165	110 5320-434	REPAIR OF VEH:	REPLACE SUSPENSION	150790	50.03
01-001213	DIESEL SPEED REPAIR, I	I-19186	110 5320-434	REPAIR OF VEH:	INSPECT, TRANSMISSIO	150790	85.55
01-001213	DIESEL SPEED REPAIR, I	I-19194	110 5320-434	REPAIR OF VEH:	REPAIR LIGHTS	150790	12.50
					VENDOR 01-001213 TOTALS		148.08
01-001331	OWEN MOTOR SPORTS INC.	I-50080642	110 5320-318	VEHICLE PARTS:	WASH 2021 KAWASAKI	150844	16.62
					VENDOR 01-001331 TOTALS		16.62
01-001787	BROWN'S AUTO SALES OF	I-784	110 5320-434	REPAIR OF VEH:	UNIT 501 REPAIRS	150763	67.48
					VENDOR 01-001787 TOTALS		67.48
01-002194	IL POWER MARKETING DBA	I-1461321111	110 5320-321	UTILITIES	: 401 DEWITT AVE EAST	150813	66.24
					VENDOR 01-002194 TOTALS		66.24

VENDOR SET: 01 CITY OF MATTOON

BANK: APBNK

FUND : 110 GENERAL FUND

DEPARTMENT: 320 STREETS

INVOICE DATE RANGE: 1/01/1998 THRU 99/99/9999

PAY DATE RANGE: 12/08/2021 THRU 12/21/2021

BUDGET TO USE: CB-CURRENT BUDGET

VENDOR	NAME	ITEM #	G/L ACCOUNT	NAME	DESCRIPTION	CHECK #	AMOUNT
01-002541	MLB OUTDOOR PRODUCTS	I-49790	110 5320-316	TOOLS & EQUIP:	REMOVE CARB & CLEAN	150838	28.00
01-002541	MLB OUTDOOR PRODUCTS	I-49880	110 5320-316	TOOLS & EQUIP:	SHARPEN CHAIN SAW	150838	65.16
						VENDOR 01-002541 TOTALS	93.16
01-002990	CINTAS	I-5085407566	110 5320-313	MEDICAL & SAF:	MEDICAL SUPPLIES	150770	31.92
						VENDOR 01-002990 TOTALS	31.92
01-003095	ADVANCE AUTO PARTS	I-202112160824	110 5320-316	TOOLS & EQUIP:	COUPLER,BRAKE FLUID	150750	11.34
01-003095	ADVANCE AUTO PARTS	I-202112160824	110 5320-318	VEHICLE PARTS:	COUPLER,BRAKE FLUID	150750	52.54
						VENDOR 01-003095 TOTALS	63.88
01-003206	BIRKEYS	I-P33478	110 5320-316	TOOLS & EQUIP:	BIRKEYS	150761	11.33
01-003206	BIRKEYS	I-W30616	110 5320-318	VEHICLE PARTS:	TRASH PUMP REPAIRS	150761	23.27
01-003206	BIRKEYS	I-W30640	110 5320-318	VEHICLE PARTS:	TRASH PUMP REPAIRS	150761	30.50
						VENDOR 01-003206 TOTALS	65.10
01-003488	SSC SERVICES, INC.	I-8298	110 5320-460	OTHER PROP MA:	JANITORIAL SERVICES	150861	233.33
						VENDOR 01-003488 TOTALS	233.33
01-003646	SCHEFF'S OFFICE SUPPLI	I-2169	110 5320-311	OFFICE SUPPLI:	OFFICE SUPPLIES	150855	33.11
01-003646	SCHEFF'S OFFICE SUPPLI	I-2215	110 5320-311	OFFICE SUPPLI:	WALL CALENDAR	150855	7.32
						VENDOR 01-003646 TOTALS	40.43
01-003660	TRUELINE COMMUNICATION	I-T1411	110 5320-433	REPAIR OF MAC:	INSTALL RADIO IN TRU	150868	267.66
						VENDOR 01-003660 TOTALS	267.66
01-003762	XEROX FINANCIAL SERVIC	I-2969997	110 5320-814	PRINT/COPY MA:	LEASE & USE	150880	43.05
						VENDOR 01-003762 TOTALS	43.05
01-003865	ALEX FUQUA	I-DEC2021-CELLAF	110 5320-533	CELLULAR PHON:	CELL PHONE	150799	16.66
						VENDOR 01-003865 TOTALS	16.66

VENDOR SET: 01 CITY OF MATTOON

BANK: APBNK

FUND : 110 GENERAL FUND

DEPARTMENT: 320 STREETS

INVOICE DATE RANGE: 1/01/1998 THRU 99/99/9999

PAY DATE RANGE: 12/08/2021 THRU 12/21/2021

BUDGET TO USE: CB-CURRENT BUDGET

VENDOR	NAME	ITEM #	G/L ACCOUNT	NAME	DESCRIPTION	CHECK #	AMOUNT
01-004298	WM CORPORATE SERVICES,	I-0000187-4072-0	110 5320-460	OTHER PROP MA:	TRASH SERVICES	003984	41.47
					VENDOR 01-004298	TOTALS	41.47
01-004910	BRIAN BUTLER	I-202112150802	110 5320-313	MEDICAL & SAF:	REIMBURSE BOOTS	150765	25.00
					VENDOR 01-004910	TOTALS	25.00
01-011600	DEBUHR'S SEED STORE	I-42526	110 5320-315	LANDSCAPING S:	STRAW	150787	20.97
					VENDOR 01-011600	TOTALS	20.97
01-012025	DETECTION SECURITY CO	I-178059	110 5320-432	REPAIR OF BUI:	ALARM MONITORING	150789	96.00
					VENDOR 01-012025	TOTALS	96.00
01-016000	JOHN DEERE FINANCIAL	I-202112160829	110 5320-316	TOOLS & EQUIP:	RATCHETING TIES	150819	10.99
01-016000	JOHN DEERE FINANCIAL	I-202112160829	110 5320-316	TOOLS & EQUIP:	FUEL CAN	150819	6.99
					VENDOR 01-016000	TOTALS	17.98
01-020607	KEVIN HAMILTON	I-DEC2021-CELLKH	110 5320-533	CELLULAR PHON:	CELL PHONE	150804	16.67
					VENDOR 01-020607	TOTALS	16.67
01-023800	CONSOLIDATED COMMUNICA	I-202112100762	110 5320-532	TELEPHONE	: 235-5460	003938	178.81
					VENDOR 01-023800	TOTALS	178.81
01-025600	ILMO PRODUCTS COMPANY	I-01249718	110 5320-440	RENTALS	: CYLINDER RENTAL	150814	8.80
					VENDOR 01-025600	TOTALS	8.80
01-026400	INDUSTRIAL SERVICES OF	I-26394	110 5320-319	MISCELLANEOUS:	RAILING BASE PLATES	150817	483.00
					VENDOR 01-026400	TOTALS	483.00

VENDOR SET: 01 CITY OF MATTOON

BANK: APBNK

FUND : 110 GENERAL FUND

DEPARTMENT: 320 STREETS

INVOICE DATE RANGE: 1/01/1998 THRU 99/99/9999

PAY DATE RANGE: 12/08/2021 THRU 12/21/2021

BUDGET TO USE: CB-CURRENT BUDGET

VENDOR	NAME	ITEM #	G/L ACCOUNT	NAME	DESCRIPTION	CHECK #	AMOUNT
01-030000	KULL LUMBER CO	I-202112160820	110 5320-316	TOOLS & EQUIP:	TAPE MEASURES	150821	14.81
					VENDOR 01-030000	TOTALS	14.81
01-030083	LANMAN OIL CO INC	I-472118	110 5320-326	FUEL	: GAS	150826	4.00
					VENDOR 01-030083	TOTALS	4.00
01-031000	LORENZ SUPPLY CO.	I-565141	110 5320-311	OFFICE SUPPLI:	LINERS,TOWELS	150828	91.98
					VENDOR 01-031000	TOTALS	91.98
01-033800	MATTOON WATER DEPT	I-202112100773	110 5320-321	UTILITIES	: 420 N LOGAN	003948	33.24
01-033800	MATTOON WATER DEPT	I-202112160830	110 5320-321	UTILITIES	: 401 DEWITT	003978	31.22
					VENDOR 01-033800	TOTALS	64.46
01-038300	PERRY'S LOCKSMITH	I-33-78391	110 5320-311	OFFICE SUPPLI:	KEYS	150848	23.33
					VENDOR 01-038300	TOTALS	23.33
01-039600	NEAL TIRE & AUTO SERVI	I-202112160825	110 5320-433	REPAIR OF MAC:	TIRES	150842	1,491.61
					VENDOR 01-039600	TOTALS	1,491.61
01-040467	SAFETY COMPLIANCE	I-34466	110 5320-313	MEDICAL & SAF:	TIE BACK RINGS	150853	13.33
01-040467	SAFETY COMPLIANCE	I-34470	110 5320-313	MEDICAL & SAF:	GLOVES	150853	15.71
01-040467	SAFETY COMPLIANCE	I-34490	110 5320-313	MEDICAL & SAF:	CONSTRUCTION HARNESS	150853	40.00
					VENDOR 01-040467	TOTALS	69.04
01-044325	TERMINIX	I-570623	110 5320-460	OTHER PROP MA:	PEST CONTROL	150864	31.66
					VENDOR 01-044325	TOTALS	31.66
DEPARTMENT 320 STREETS						TOTAL:	7,240.03

VENDOR SET: 01 CITY OF MATTOON

BANK: APBNK

FUND : 110 GENERAL FUND

DEPARTMENT: 381 CUSTODIAL SERVICES

INVOICE DATE RANGE: 1/01/1998 THRU 99/99/9999

PAY DATE RANGE: 12/08/2021 THRU 12/21/2021

BUDGET TO USE: CB-CURRENT BUDGET

VENDOR	NAME	ITEM #	G/L ACCOUNT	NAME	DESCRIPTION	CHECK #	AMOUNT
01-000720	CARDMEMBER SERVICES	I-202112160828	110 5381-319	MISCELLANEOUS:	FILTER OUTLET	150768	594.80
01-000720	CARDMEMBER SERVICES	I-202112160828	110 5381-319	MISCELLANEOUS:	FILTER OUTLET	150768	77.62
						VENDOR 01-000720 TOTALS	672.42
01-001070	AMEREN ILLINOIS	I-202112100740	110 5381-321	UTILITIES	: 19TH ST	003917	23.93
						VENDOR 01-001070 TOTALS	23.93
01-002194	IL POWER MARKETING DBA	I-1461321111	110 5381-321	UTILITIES	: 1718 B'DWAY UNIT B	150813	90.90
01-002194	IL POWER MARKETING DBA	I-1461321111	110 5381-321	UTILITIES	: 1701 B'DWAY	150813	111.01
01-002194	IL POWER MARKETING DBA	I-1461321111	110 5381-321	UTILITIES	: CITY HALL	150813	499.27
01-002194	IL POWER MARKETING DBA	I-1461321111	110 5381-321	UTILITIES	: 208 N 19TH	150813	10.22
01-002194	IL POWER MARKETING DBA	I-1461321111	110 5381-321	UTILITIES	: 19TH ST LIGHTS	150813	15.24
01-002194	IL POWER MARKETING DBA	I-1461321111	110 5381-321	UTILITIES	: BURGESS	150813	47.27
						VENDOR 01-002194 TOTALS	773.91
01-002250	COMMERCIAL REFRIGERATI	I-47743	110 5381-432	REPAIR OF BUI:	DEPOT REPAIRS	150782	470.92
						VENDOR 01-002250 TOTALS	470.92
01-002776	PALS ELECTRIC INC.	I-12529	110 5381-432	REPAIR OF BUI:	RETROFIT DEPOT LIGHT	150845	4,826.83
						VENDOR 01-002776 TOTALS	4,826.83
01-003488	SSC SERVICES, INC.	I-8300	110 5381-460	OTHER PROP MA:	JANITORIAL SERVICES	150861	268.00
01-003488	SSC SERVICES, INC.	I-8304	110 5381-460	OTHER PROP MA:	JANITORIAL SERVICES	150861	268.00
						VENDOR 01-003488 TOTALS	536.00
01-033800	MATTOON WATER DEPT	I-202112100771	110 5381-321	UTILITIES	: 208 N 19TH	003946	220.70
01-033800	MATTOON WATER DEPT	I-202112100788	110 5381-321	UTILITIES	: 1701 B'DWAY	003963	43.10
01-033800	MATTOON WATER DEPT	I-202112100789	110 5381-321	UTILITIES	: 1701 WABASH	003964	39.26
						VENDOR 01-033800 TOTALS	303.06
DEPARTMENT 381 CUSTODIAL SERVICES						TOTAL:	7,607.07

VENDOR SET: 01 CITY OF MATTOON

BANK: APBNK

FUND : 110 GENERAL FUND

DEPARTMENT: 511 PARKS

INVOICE DATE RANGE: 1/01/1998 THRU 99/99/9999

PAY DATE RANGE: 12/08/2021 THRU 12/21/2021

BUDGET TO USE: CB-CURRENT BUDGET

VENDOR	NAME	ITEM #	G/L ACCOUNT	NAME	DESCRIPTION	CHECK #	AMOUNT
01-001070	AMEREN ILLINOIS	I-202112100742	110 5511-321	UTILITIES	: 311 N 6TH	003919	34.84
01-001070	AMEREN ILLINOIS	I-202112100748	110 5511-321	UTILITIES	: 1200 CHAMPAIGN	003925	24.73
01-001070	AMEREN ILLINOIS	I-202112100755	110 5511-321	UTILITIES	: 500 B'DWAY	003932	155.53
						VENDOR 01-001070 TOTALS	215.10
01-002194	IL POWER MARKETING DBA I-1461321111		110 5511-321	UTILITIES	: 1200 CHAMPAIGN	150813	13.39
01-002194	IL POWER MARKETING DBA I-1461321111		110 5511-321	UTILITIES	: PETERSON PARK	150813	122.32
01-002194	IL POWER MARKETING DBA I-1461321111		110 5511-321	UTILITIES	: 212 N 12TH	150813	18.41
01-002194	IL POWER MARKETING DBA I-1461321111		110 5511-321	UTILITIES	: LAWSON PARK	150813	71.93
01-002194	IL POWER MARKETING DBA I-1461321111		110 5511-321	UTILITIES	: PETERSON PARK	150813	160.89
01-002194	IL POWER MARKETING DBA I-1461321111		110 5511-321	UTILITIES	: 500 B'DWAY	150813	3.79
						VENDOR 01-002194 TOTALS	390.73
01-002414	CCI REDIMIX	I-334897	110 5511-825	TOURISM GRANT:	PETERSON SIDEWALK	150769	2,288.38
						VENDOR 01-002414 TOTALS	2,288.38
01-002934	SOUTH CENTRAL FS, INC. I-6721401		110 5511-326	FUEL	: FUEL	150859	495.75
						VENDOR 01-002934 TOTALS	495.75
01-003142	VARNER & RAWLINGS	I-10381	110 5511-432	REPAIR OF BUI:	FURNACE REPAIRS	150874	301.43
01-003142	VARNER & RAWLINGS	I-3853	110 5511-432	REPAIR OF BUI:	FURNACE REPAIRS	150874	211.23
01-003142	VARNER & RAWLINGS	I-HH92879	110 5511-432	REPAIR OF BUI:	INSTALL HANGING HEAT	150874	1,950.00
						VENDOR 01-003142 TOTALS	2,462.66
01-003206	BIRKEYS	I-P35267	110 5511-316	TOOLS & EQUIP:	TRIMMER	150761	20.82
01-003206	BIRKEYS	I-W30762	110 5511-433	REPAIR OF MAC:	TRACTOR REPAIRS	150761	1,194.42
						VENDOR 01-003206 TOTALS	1,215.24
01-011600	DEBUHR'S SEED STORE	I-42655	110 5511-319	MISCELLANEOUS:	PEST SPRAY	150787	13.99
						VENDOR 01-011600 TOTALS	13.99
01-020803	HARRELSON PLUMBING & H I-M1451		110 5511-440	RENTALS	: POTTY RENTALS	150805	80.00
						VENDOR 01-020803 TOTALS	80.00

VENDOR SET: 01 CITY OF MATTOON

BANK: APBNK

FUND : 110 GENERAL FUND

DEPARTMENT: 511 PARKS

INVOICE DATE RANGE: 1/01/1998 THRU 99/99/9999

PAY DATE RANGE: 12/08/2021 THRU 12/21/2021

BUDGET TO USE: CB-CURRENT BUDGET

VENDOR	NAME	ITEM #	G/L ACCOUNT	NAME	DESCRIPTION	CHECK #	AMOUNT
01-021402	3 SISTERS LOGISTICS, L	I-79030	110 5511-825	TOURISM GRANT:	AG LIME	150749	382.86
					VENDOR 01-021402 TOTALS		382.86
01-023800	CONSOLIDATED COMMUNICA	I-202112100756	110 5511-532	TELEPHONE	: 234-3611	003933	84.24
					VENDOR 01-023800 TOTALS		84.24
01-025600	ILMO PRODUCTS COMPANY	I-01252501	110 5511-319	MISCELLANEOUS:	WELDING SUPPLIES	150814	60.81
01-025600	ILMO PRODUCTS COMPANY	I-01252696	110 5511-319	MISCELLANEOUS:	WELDING SUPPLIES	150814	124.02
					VENDOR 01-025600 TOTALS		184.83
01-030000	KULL LUMBER CO	I-202112150796	110 5511-319	MISCELLANEOUS:	FASTENERS	150821	6.07
					VENDOR 01-030000 TOTALS		6.07
01-033800	MATTOON WATER DEPT	I-202112100781	110 5511-321	UTILITIES	: 500 BROADWAY	003956	9.54
01-033800	MATTOON WATER DEPT	I-202112100782	110 5511-321	UTILITIES	: 500 B'DWAY	003957	17.52
01-033800	MATTOON WATER DEPT	I-202112100783	110 5511-321	UTILITIES	: 500 B'DWAY	003958	44.19
01-033800	MATTOON WATER DEPT	I-202112100784	110 5511-321	UTILITIES	: 418 RICHMOND	003959	22.22
01-033800	MATTOON WATER DEPT	I-202112100785	110 5511-321	UTILITIES	: 212 N 12TH	003960	9.54
					VENDOR 01-033800 TOTALS		103.01

DEPARTMENT 511 PARKS TOTAL: 7,922.86

01-003206	BIRKEYS	I-W30814	110 5512-433	REPAIR OF MAC:	STIHL SAW REPAIRS	150761	37.25
					VENDOR 01-003206 TOTALS		37.25
01-006875	CLASSIC PRINTING	I-62127	110 5512-317	CONCESSION &	: BOAT STICKER DECALS	150772	1,697.50
					VENDOR 01-006875 TOTALS		1,697.50
01-012025	DETECTION SECURITY CO	I-178047	110 5512-576	SECURITY SERV:	MARINA SECURITY	150789	47.00
					VENDOR 01-012025 TOTALS		47.00

VENDOR SET: 01 CITY OF MATTOON

BANK: APBNK

FUND : 110 GENERAL FUND

DEPARTMENT: 512 LAKE MATTOON

INVOICE DATE RANGE: 1/01/1998 THRU 99/99/9999

PAY DATE RANGE: 12/08/2021 THRU 12/21/2021

BUDGET TO USE: CB-CURRENT BUDGET

VENDOR	NAME	ITEM #	G/L ACCOUNT	NAME	DESCRIPTION	CHECK #	AMOUNT
01-017400	TSYS	I-202112150805	110 5512-319	MISCELLANEOUS:	LAKE 11/2021 CC FEES	003980	62.23
					VENDOR 01-017400 TOTALS		62.23
01-020534	FRONTIER	I-202112150803	110 5512-532	TELEPHONE	: 895-2922	150797	68.37
					VENDOR 01-020534 TOTALS		68.37
01-020803	HARRELSON PLUMBING & H	I-M1452	110 5512-440	RENTALS	: POTTY RENTAL	150805	80.00
					VENDOR 01-020803 TOTALS		80.00
01-030065	LAKE MATTOON PUBLIC WA	I-202112160860	110 5512-321	UTILITIES	: 1290 CO RD 000 EAST	150825	18.00
01-030065	LAKE MATTOON PUBLIC WA	I-202112160861	110 5512-321	UTILITIES	: 2 CO RD 1200 NORTH R	150825	18.00
01-030065	LAKE MATTOON PUBLIC WA	I-202112160862	110 5512-321	UTILITIES	: 1298 CO MRD 000 EAST	150825	18.00
01-030065	LAKE MATTOON PUBLIC WA	I-202112160863	110 5512-321	UTILITIES	: 3586 975 NORTH RD	150825	18.00
					VENDOR 01-030065 TOTALS		72.00
01-041755	SHELBY ELECTRIC COOPER	I-202112100790	110 5512-321	UTILITIES	: RESTROOMS	003965	75.53
01-041755	SHELBY ELECTRIC COOPER	I-202112100791	110 5512-321	UTILITIES	: HUFFMANS	003966	197.08
01-041755	SHELBY ELECTRIC COOPER	I-202112100792	110 5512-321	UTILITIES	: MARINA	003967	196.39
01-041755	SHELBY ELECTRIC COOPER	I-202112100793	110 5512-321	UTILITIES	: CAMPGROUND	003968	163.92
01-041755	SHELBY ELECTRIC COOPER	I-202112100794	110 5512-321	UTILITIES	: NEW TRF	003969	150.80
01-041755	SHELBY ELECTRIC COOPER	I-202112100795	110 5512-321	UTILITIES	: CAUSEWAY BRIDGE	003970	232.70
					VENDOR 01-041755 TOTALS		1,016.42
				DEPARTMENT 512	LAKE MATTOON	TOTAL:	3,080.77
01-001070	AMEREN ILLINOIS	I-202112100741	110 5551-321	UTILITIES	: 221 SHELBY	003918	160.48
01-001070	AMEREN ILLINOIS	I-202112100743	110 5551-321	UTILITIES	: 312 N 10TH ST	003920	27.66
01-001070	AMEREN ILLINOIS	I-202112100744	110 5551-321	UTILITIES	: 421 SHELBY	003921	229.44
01-001070	AMEREN ILLINOIS	I-202112100745	110 5551-321	UTILITIES	: 312 N 10TH	003922	167.94
01-001070	AMEREN ILLINOIS	I-202112100746	110 5551-321	UTILITIES	: 311 N 6TH ST	003923	215.75
					VENDOR 01-001070 TOTALS		801.27
01-002194	IL POWER MARKETING DBA	I-1461321111	110 5551-321	UTILITIES	: T-BALL COMPLEX	150813	66.86

VENDOR SET: 01 CITY OF MATTOON

BANK: APBNK

FUND : 110 GENERAL FUND

DEPARTMENT: 551 SPORTS FACILITIES

INVOICE DATE RANGE: 1/01/1998 THRU 99/99/9999

PAY DATE RANGE: 12/08/2021 THRU 12/21/2021

BUDGET TO USE: CB-CURRENT BUDGET

VENDOR	NAME	ITEM #	G/L ACCOUNT	NAME	DESCRIPTION	CHECK #	AMOUNT
01-002194	IL POWER MARKETING DBA I-1461321111		110 5551-321	UTILITIES	: KINZEL FIELD	150813	14.81
01-002194	IL POWER MARKETING DBA I-1461321111		110 5551-321	UTILITIES	: JFL COMPLEX	150813	132.50
01-002194	IL POWER MARKETING DBA I-1461321111		110 5551-321	UTILITIES	: BOYS COMPLEX	150813	60.57
01-002194	IL POWER MARKETING DBA I-1461321111		110 5551-321	UTILITIES	: GIRLS COMPLEX	150813	98.43
						VENDOR 01-002194 TOTALS	373.17
01-020803	HARRELSON PLUMBING & H I-M1449		110 5551-440	RENTALS	: POTTY RENTAL	150805	80.00
01-020803	HARRELSON PLUMBING & H I-M1450		110 5551-440	RENTALS	: POTTY RENTAL	150805	80.00
						VENDOR 01-020803 TOTALS	160.00
01-033800	MATTOON WATER DEPT I-202112100774		110 5551-321	UTILITIES	: 713 SHELBY	003949	169.04
01-033800	MATTOON WATER DEPT I-202112100775		110 5551-321	UTILITIES	: 801 SHELBY	003950	415.45
01-033800	MATTOON WATER DEPT I-202112100776		110 5551-321	UTILITIES	: 421 SHELBY	003951	351.71
01-033800	MATTOON WATER DEPT I-202112100777		110 5551-321	UTILITIES	: 421 SHELBY	003952	154.47
01-033800	MATTOON WATER DEPT I-202112100778		110 5551-321	UTILITIES	: 301 RICHMOND	003953	16.18
01-033800	MATTOON WATER DEPT I-202112100779		110 5551-321	UTILITIES	: 305 RICHMOND	003954	15.30
01-033800	MATTOON WATER DEPT I-202112100780		110 5551-321	UTILITIES	: 307 RICHMOND	003955	41.78
						VENDOR 01-033800 TOTALS	1,163.93
DEPARTMENT 551 SPORTS FACILITIES						TOTAL:	2,498.37
01-001070	AMEREN ILLINOIS I-202112100747		110 5570-321	UTILITIES	: 917 N 22ND	003924	127.41
						VENDOR 01-001070 TOTALS	127.41
01-002194	IL POWER MARKETING DBA I-1461321111		110 5570-321	UTILITIES	: 917 N 22ND	150813	2.32
01-002194	IL POWER MARKETING DBA I-1461321111		110 5570-321	UTILITIES	: CEMETERY	150813	10.84
						VENDOR 01-002194 TOTALS	13.16
01-002934	SOUTH CENTRAL FS, INC. I-6721400		110 5570-326	FUEL	: FUEL	150859	668.17
						VENDOR 01-002934 TOTALS	668.17
01-003206	BIRKEYS I-W30764		110 5570-433	REPAIR OF MAC:	TRASH PUMP REPAIRS	150761	212.88
01-003206	BIRKEYS I-W30815		110 5570-433	REPAIR OF MAC:	STIHL BLOWER REPAIRS	150761	100.70
						VENDOR 01-003206 TOTALS	313.58

VENDOR SET: 01 CITY OF MATTOON

BANK: APBNK

FUND : 110 GENERAL FUND

DEPARTMENT: 570 DODGE GROVE CEMETERY

INVOICE DATE RANGE: 1/01/1998 THRU 99/99/9999

PAY DATE RANGE: 12/08/2021 THRU 12/21/2021

BUDGET TO USE: CB-CURRENT BUDGET

VENDOR	NAME	ITEM #	G/L ACCOUNT	NAME	DESCRIPTION	CHECK #	AMOUNT
01-023800	CONSOLIDATED COMMUNICA	I-202112100760	110 5570-532	TELEPHONE	: 234-2055	003937	78.46
VENDOR 01-023800 TOTALS							78.46
01-030000	KULL LUMBER CO	I-202112150796	110 5570-319	MISCELLANEOUS: PAINT		150821	7.59
01-030000	KULL LUMBER CO	I-202112150798	110 5570-319	MISCELLANEOUS: SILICONE, CAULK GUN		150821	22.17
VENDOR 01-030000 TOTALS							29.76
01-033800	MATTOON WATER DEPT	I-202112100770	110 5570-321	UTILITIES	: N 19TH	003945	7.65
01-033800	MATTOON WATER DEPT	I-202112100772	110 5570-321	UTILITIES	: 917 N 22ND	003947	16.39
VENDOR 01-033800 TOTALS							24.04
01-037050	NIEMEYER REPAIR SERVIC	I-61421	110 5570-433	REPAIR OF MAC: SWELL LATCH ASSEMBLY		150843	96.90
VENDOR 01-037050 TOTALS							96.90
DEPARTMENT 570 DODGE GROVE CEMETERY						TOTAL:	1,351.48
01-008801	COLES TOGETHER	I-DEC2021-PLEDGE	110 5651-571	DUES & MEMBER: PLEDGE		150780	4,166.66
VENDOR 01-008801 TOTALS							4,166.66
DEPARTMENT 651 ECONOMIC DEVELOPMENT						TOTAL:	4,166.66
VENDOR SET 110 GENERAL FUND						TOTAL:	148,539.87

VENDOR SET: 01 CITY OF MATTOON

BANK: APBNK

FUND : 122 HOTEL TAX FUND

DEPARTMENT: 653 HOTEL TAX ADMINISTRATION

INVOICE DATE RANGE: 1/01/1998 THRU 99/99/9999

PAY DATE RANGE: 12/08/2021 THRU 12/21/2021

BUDGET TO USE: CB-CURRENT BUDGET

VENDOR	NAME	ITEM #	G/L ACCOUNT	NAME	DESCRIPTION	CHECK #	AMOUNT
01-001070	AMEREN ILLINOIS	I-202112100749	122 5653-321	NATURAL GAS &:	4219 DEWITT WELCOME	003926	30.64
01-001070	AMEREN ILLINOIS	I-202112100752	122 5653-321	NATURAL GAS &:	3901 MARSHALL AVE SI	003929	27.22
						VENDOR 01-001070 TOTALS	57.86
01-001235	ANGELIA D BURGETT	I-202112160819	122 5653-562	TRAVEL & TRAI:	MILEAGE 12/5-12/8	150764	140.00
01-001235	ANGELIA D BURGETT	I-DEC2021-CELLAB	122 5653-533	CELLULAR PHON:	CELL PHONE	150764	100.00
						VENDOR 01-001235 TOTALS	240.00
01-001663	ADVANCED DIGITAL SOLUT	I-IN35613	122 5653-814	PRINTING/COPY:	XEROX C405	150751	51.35
						VENDOR 01-001663 TOTALS	51.35
01-001735	ICCVB	I-1346	122 5653-571	DUES & MEMBER:	MEMBERSHIP	150808	1,000.00
						VENDOR 01-001735 TOTALS	1,000.00
01-002194	IL POWER MARKETING DBA	I-1461321111	122 5653-321	NATURAL GAS &:	1718 B'DWAY UNIT C	150813	52.38
01-002194	IL POWER MARKETING DBA	I-1461321111	122 5653-321	NATURAL GAS &:	4219 DEWITT	150813	4.02
						VENDOR 01-002194 TOTALS	56.40
01-003328	DOEHRING, WINDERS & CO	I-202112150812	122 5653-513	AUDITING SERV:	AUDITING SERVICES	150791	1,350.00
						VENDOR 01-003328 TOTALS	1,350.00
01-003425	THE CATHOLIC READER	I-202112160856	122 5653-540	ADVERTISING :	FULL PAGE AD	150866	347.00
						VENDOR 01-003425 TOTALS	347.00
01-017400	TSYS	I-202112150806	122 5653-311	OFFICE SUPPLI:	TOURISM 11/2021 CC F	003981	116.15
						VENDOR 01-017400 TOTALS	116.15
01-023800	CONSOLIDATED COMMUNICA	I-202112100758	122 5653-532	TELEPHONE :	800-500-6286	003935	6.10
						VENDOR 01-023800 TOTALS	6.10

DEPARTMENT 653 HOTEL TAX ADMINISTRATION TOTAL: 3,224.86

VENDOR SET 122 HOTEL TAX FUND TOTAL: 3,224.86

VENDOR SET: 01 CITY OF MATTOON
 FUND : 123 FESTIVAL MGMT FUND
 DEPARTMENT: 584 BAGELFEST
 INVOICE DATE RANGE: 1/01/1998 THRU 99/99/9999
 PAY DATE RANGE: 12/08/2021 THRU 12/21/2021
 BUDGET TO USE: CB-CURRENT BUDGET

BANK: APBNK

VENDOR	NAME	ITEM #	G/L ACCOUNT	NAME	DESCRIPTION	CHECK #	AMOUNT
01-000930	BMI GENERAL LICENSING	I-41601577	123 5584-834	ENTERTAINMENT:	LICENSING FEE	150762	379.22
						VENDOR 01-000930 TOTALS	379.22
DEPARTMENT 584 BAGELFEST						TOTAL:	379.22
01-000684	ULINE	I-141688375	123 5586-432	REPAIR OF STR:	VINYL DOOR KIT	150871	329.37
						VENDOR 01-000684 TOTALS	329.37
01-000720	CARDMEMBER SERVICES	I-202112160828	123 5586-540	ADVERTISING :	FACEBOOK	150768	50.00
						VENDOR 01-000720 TOTALS	50.00
01-030000	KULL LUMBER CO	I-202112150796	123 5586-316	TOOLS & EQUIP:	PVC,DONDUIT,ALCOHOL	150821	168.09
						VENDOR 01-030000 TOTALS	168.09
01-045603	WMCI/WCBH/WWGO	I-235-00205-0000	123 5586-540	ADVERTISING :	LIGHTWORKS ADVERTISI	150877	175.00
01-045603	WMCI/WCBH/WWGO	I-235-00206-0000	123 5586-540	ADVERTISING :	LIGHTWORKS ADVERTISI	150877	120.00
01-045603	WMCI/WCBH/WWGO	I-235-00207-0000	123 5586-540	ADVERTISING :	LIGHTWORKS ADVERTISI	150877	125.00
						VENDOR 01-045603 TOTALS	420.00
DEPARTMENT 586 LIGHTWORKS						TOTAL:	967.46
VENDOR SET 123 FESTIVAL MGMT FUND						TOTAL:	1,346.68

VENDOR SET: 01 CITY OF MATTOON

BANK: APBNK

FUND : 124 MOBILE EQUIPMENT FUND

DEPARTMENT: 342 SEWER COLL VEH & MACH

INVOICE DATE RANGE: 1/01/1998 THRU 99/99/9999

PAY DATE RANGE: 12/08/2021 THRU 12/21/2021

BUDGET TO USE: CB-CURRENT BUDGET

VENDOR	NAME	ITEM #	G/L ACCOUNT	NAME	DESCRIPTION	CHECK #	AMOUNT
01-003748	MORROW BROTHERS FORD,	I-202112100734	124 5342-742	SEWER COLLECT:	(4) 1 TON TUCKS	150717	48,970.00
						VENDOR 01-003748 TOTALS	48,970.00
						DEPARTMENT 342 SEWER COLL VEH & MACH TOTAL:	48,970.00
01-003748	MORROW BROTHERS FORD,	I-202112100734	124 5344-742	WASTEWATER TR:	(4) 1 TON TUCKS	150717	52,780.00
						VENDOR 01-003748 TOTALS	52,780.00
						DEPARTMENT 344 WASTEWATER TRTMT VEH & MATOTAL:	52,780.00
01-003748	MORROW BROTHERS FORD,	I-202112100734	124 5353-742	WATER TREATME:	(4) 1 TON TUCKS	150717	52,780.00
						VENDOR 01-003748 TOTALS	52,780.00
						DEPARTMENT 353 WATER TRTMT VEH & MACH TOTAL:	52,780.00
01-003748	MORROW BROTHERS FORD,	I-202112100734	124 5354-742	WATER DIST VE:	(4) 1 TON TUCKS	150717	48,970.00
						VENDOR 01-003748 TOTALS	48,970.00
						DEPARTMENT 354 WATER VEHICLES & MACHINE TOTAL:	48,970.00
						VENDOR SET 124 MOBILE EQUIPMENT FUND TOTAL:	203,500.00

VENDOR SET: 01 CITY OF MATTOON

BANK: APBNK

FUND : 125 INSURANCE & TORT JDGMNT

DEPARTMENT: 150 FINANCIAL ADMINISTRATION

INVOICE DATE RANGE: 1/01/1998 THRU 99/99/9999

PAY DATE RANGE: 12/08/2021 THRU 12/21/2021

BUDGET TO USE: CB-CURRENT BUDGET

VENDOR	NAME	ITEM #	G/L ACCOUNT	NAME	DESCRIPTION	CHECK #	AMOUNT
01-002776	PALS ELECTRIC INC.	I-12446	125 5150-527	SELF INSURED :	DETTRO & CHARLESTON	150845	7,219.80
						VENDOR 01-002776 TOTALS	7,219.80
01-023915	IL COUNTIES RISK MANAG	I-28382	125 5150-523	PROPERTY & CA:	PROPERTY & LIABILITY	150811	81,058.75
01-023915	IL COUNTIES RISK MANAG	I-28552	125 5150-523	PROPERTY & CA:	PROPERTY & LIABILITY	150811	40,529.38
01-023915	IL COUNTIES RISK MANAG	I-29118	125 5150-250	WORKERS' COMP:	WORKERS COMP PREMIUM	150811	135,375.00
01-023915	IL COUNTIES RISK MANAG	I-29262	125 5150-250	WORKERS' COMP:	WORKERS COMP PREMIUM	150811	67,687.50
						VENDOR 01-023915 TOTALS	324,650.63
01-040463	SARAH BUSH LINCOLN HEA	I-4519731	125 5150-519	OTHER PROFESS:	DRUG SCREENS	150854	78.00
						VENDOR 01-040463 TOTALS	78.00
DEPARTMENT 150 FINANCIAL ADMINISTRATION TOTAL:							331,948.43

VENDOR SET 125 INSURANCE & TORT JDGMNT TOTAL:							331,948.43

VENDOR SET: 01 CITY OF MATTOON

BANK: APBNK

FUND : 128 MIDTOWN TIF FUND

DEPARTMENT: 604 MIDTOWN TIF DISTRICT

INVOICE DATE RANGE: 1/01/1998 THRU 99/99/9999

PAY DATE RANGE: 12/08/2021 THRU 12/21/2021

BUDGET TO USE: CB-CURRENT BUDGET

VENDOR	NAME	ITEM #	G/L ACCOUNT	NAME	DESCRIPTION	CHECK #	AMOUNT
01-000731	MATTOON COMMUNITY UNIT	I-202112160831	128 5604-821	SHARED INCREM:	MIDTOWN TIF	150830	79,255.31
					VENDOR 01-000731 TOTALS		79,255.31
01-000732	LAKE LAND COLLEGE	I-202112160833	128 5604-821	SHARED INCREM:	MIDTOWN TIF	150823	11,310.22
					VENDOR 01-000732 TOTALS		11,310.22
01-000733	MATTOON TOWNSHIP SUPER	I-202112160834	128 5604-821	SHARED INCREM:	MIDTOWN TIF	150834	3,190.12
01-000733	MATTOON TOWNSHIP SUPER	I-202112160835	128 5604-821	SHARED INCREM:	MIDTOWN TIF	150834	3,974.69
					VENDOR 01-000733 TOTALS		7,164.81
01-000734	MATTOON PARK DISTRICT	I-202112160836	128 5604-821	SHARED INCREM:	MIDTOWN TIF	150832	5,189.09
					VENDOR 01-000734 TOTALS		5,189.09
01-000812	COLES CO CLERK & RECOR	I-202112160832	128 5604-821	SHARED INCREM:	MIDTOWN TIF	150777	22,000.31
					VENDOR 01-000812 TOTALS		22,000.31
01-003328	DOEHRING, WINDERS & CO	I-202112150812	128 5604-513	AUDITING SERV:	AUDITING SERVICES	150791	1,350.00
					VENDOR 01-003328 TOTALS		1,350.00
01-003344	MATTOON FLOOR SHOW, IN	I-56130	128 5604-902	SIDEWALKS & C:	CARPET CLEANING	150831	980.00
					VENDOR 01-003344 TOTALS		980.00
01-007882	COLES CO AIRPORT AUTHO	I-202112160837	128 5604-821	SHARED INCREM:	MIDTOWN TIF	150776	1,162.91
					VENDOR 01-007882 TOTALS		1,162.91
				DEPARTMENT 604	MIDTOWN TIF DISTRICT	TOTAL:	128,412.65
				VENDOR SET 128	MIDTOWN TIF FUND	TOTAL:	128,412.65

VENDOR SET: 01 CITY OF MATTOON

BANK: APBNK

FUND : 130 CAPITAL PROJECT FUND

DEPARTMENT: 321 STREETS

INVOICE DATE RANGE: 1/01/1998 THRU 99/99/9999

PAY DATE RANGE: 12/08/2021 THRU 12/21/2021

BUDGET TO USE: CB-CURRENT BUDGET

VENDOR	NAME	ITEM #	G/L ACCOUNT	NAME	DESCRIPTION	CHECK #	AMOUNT
01-000742	BARTELS CONSTRUCTION,	I-202112150815	130 5321-730	IMPROVEMENTS :	43RD STREET PATCH	150758	15,163.20
01-000742	BARTELS CONSTRUCTION,	I-202112160857	130 5321-730	IMPROVEMENTS :	43RD STREET PATCH	150758	1,684.80
						VENDOR 01-000742 TOTALS	16,848.00
01-004013	GARY RENFRO	I-202112160826	130 5321-730	IMPROVEMENTS :	2909 SIDEWALK	150852	1,191.80
						VENDOR 01-004013 TOTALS	1,191.80
01-004179	HILD LANDSCAPING LLC	I-3799	130 5321-730	IMPROVEMENTS :	2021 FALL TREE PLANT	150806	11,140.00
						VENDOR 01-004179 TOTALS	11,140.00
01-035154	MID-ILLINOIS CONCRETE	I-243010	130 5321-730	IMPROVEMENTS :	MITCHELL JERDAN ALLE	150835	14,865.00
						VENDOR 01-035154 TOTALS	14,865.00
01-040469	DURWIN SANDERS	I-22157	130 5321-730	IMPROVEMENTS :	80 B'DWAY RAMP	150793	531.00
						VENDOR 01-040469 TOTALS	531.00
						DEPARTMENT 321 STREETS TOTAL:	44,575.80
						VENDOR SET 130 CAPITAL PROJECT FUND TOTAL:	44,575.80

VENDOR SET: 01 CITY OF MATTOON
FUND : 150 I-57 EAST TIF DISTRICT
DEPARTMENT: 800 SHARED INCREMENT
INVOICE DATE RANGE: 1/01/1998 THRU 99/99/9999
PAY DATE RANGE: 12/08/2021 THRU 12/21/2021
BUDGET TO USE: CB-CURRENT BUDGET

BANK: APBNK

VENDOR	NAME	ITEM #	G/L ACCOUNT	NAME	DESCRIPTION	CHECK #	AMOUNT
01-000731	MATTOON COMMUNITY UNIT	I-202112160838	150 5800-821	SHARED INCREM:	EAST I-57 TIF DIST	150830	2,993.97
					VENDOR 01-000731 TOTALS		2,993.97
01-000732	LAKE LAND COLLEGE	I-202112160840	150 5800-821	SHARED INCREM:	EAST I-57 TIF DIST	150823	427.26
					VENDOR 01-000732 TOTALS		427.26
01-000812	COLES CO CLERK & RECOR	I-202112160839	150 5800-821	SHARED INCREM:	EAST I-57 TIF DIST	150777	831.09
					VENDOR 01-000812 TOTALS		831.09
01-001928	LAFAYETTE TOWNSHIP	I-202112160841	150 5800-821	SHARED INCREM:	EAST I-57 TIF DIST	150822	101.84
01-001928	LAFAYETTE TOWNSHIP	I-202112160842	150 5800-821	SHARED INCREM:	EAST I-57 TIF DIST	150822	417.13
					VENDOR 01-001928 TOTALS		518.97
01-007882	COLES CO AIRPORT AUTHO	I-202112160843	150 5800-821	SHARED INCREM:	EAST I-57 TIF DIST	150776	43.93
					VENDOR 01-007882 TOTALS		43.93
				DEPARTMENT 800	SHARED INCREMENT	TOTAL:	4,815.22
				VENDOR SET 150	I-57 EAST TIF DISTRICT	TOTAL:	4,815.22

VENDOR SET: 01 CITY OF MATTOON

BANK: APBNK

FUND : 151 SOUTH RT 45 TIF DISTRICT

DEPARTMENT: 604 SOUTH RT 45 TIF DISTRICT

INVOICE DATE RANGE: 1/01/1998 THRU 99/99/9999

PAY DATE RANGE: 12/08/2021 THRU 12/21/2021

BUDGET TO USE: CB-CURRENT BUDGET

VENDOR	NAME	ITEM #	G/L ACCOUNT	NAME	DESCRIPTION	CHECK #	AMOUNT
01-000731	MATTOON COMMUNITY UNIT	I-202112160844	151 5604-821	SHARED INCREM:	S RT 45 TIF DIST	150830	6,521.66
					VENDOR 01-000731 TOTALS		6,521.66
01-000732	LAKE LAND COLLEGE	I-202112160846	151 5604-821	SHARED INCREM:	S RT 45 TIF DIST	150823	930.68
					VENDOR 01-000732 TOTALS		930.68
01-000812	COLES CO CLERK & RECOR	I-202112160845	151 5604-821	SHARED INCREM:	S RT 45 TIF DIST	150777	1,810.33
					VENDOR 01-000812 TOTALS		1,810.33
01-007882	COLES CO AIRPORT AUTHO	I-202112160849	151 5604-821	SHARED INCREM:	S RT 45 TIF DIST	150776	95.69
					VENDOR 01-007882 TOTALS		95.69
01-038000	PARADISE TOWNSHIP	I-202112160847	151 5604-821	SHARED INCREM:	S RT 45 TIF DIST	150846	328.16
01-038000	PARADISE TOWNSHIP	I-202112160848	151 5604-821	SHARED INCREM:	S RT 45 TIF DIST	150846	558.21
					VENDOR 01-038000 TOTALS		886.37

DEPARTMENT 604 SOUTH RT 45 TIF DISTRICT TOTAL: 10,244.73

VENDOR SET 151 SOUTH RT 45 TIF DISTRICT TOTAL: 10,244.73

VENDOR SET: 01 CITY OF MATTOON

BANK: APBNK

FUND : 153 BROADWAY EAST TIF DIST

DEPARTMENT: 604 BROADWAY EAST TIF DIST

INVOICE DATE RANGE: 1/01/1998 THRU 99/99/9999

PAY DATE RANGE: 12/08/2021 THRU 12/21/2021

BUDGET TO USE: CB-CURRENT BUDGET

VENDOR	NAME	ITEM #	G/L ACCOUNT	NAME	DESCRIPTION	CHECK #	AMOUNT
01-000731	MATTOON COMMUNITY UNIT	I-202112160850	153 5604-821	SHARED INCREM:	B'DWAY EAST TIF DIST	150830	17,370.92
							<hr/>
					VENDOR 01-000731	TOTALS	17,370.92
01-000732	LAKE LAND COLLEGE	I-202112160852	153 5604-821	SHARED INCREM:	B'DWAY EAST TIF DIST	150823	2,478.94
							<hr/>
					VENDOR 01-000732	TOTALS	2,478.94
01-000812	COLES CO CLERK & RECOR	I-202112160851	153 5604-821	SHARED INCREM:	B'DWAY EAST TIF DIST	150777	4,821.96
							<hr/>
					VENDOR 01-000812	TOTALS	4,821.96
01-001928	LAFAYETTE TOWNSHIP	I-202112160853	153 5604-821	SHARED INCREM:	B'DWAY EAST TIF DIST	150822	590.87
01-001928	LAFAYETTE TOWNSHIP	I-202112160854	153 5604-821	SHARED INCREM:	B'DWAY EAST TIF DIST	150822	2,420.20
							<hr/>
					VENDOR 01-001928	TOTALS	3,011.07
01-007882	COLES CO AIRPORT AUTHO	I-202112160855	153 5604-821	SHARED INCREM:	B'DWAY EAST TIF DIST	150776	254.88
							<hr/>
					VENDOR 01-007882	TOTALS	254.88

DEPARTMENT 604 BROADWAY EAST TIF DIST TOTAL: 27,937.77

VENDOR SET 153 BROADWAY EAST TIF DIST TOTAL: 27,937.77

VENDOR SET: 01 CITY OF MATTOON

BANK: APBNK

FUND : 154 BROADWAY EAST BUS DIST

DEPARTMENT: 604 BROADWAY EAST BUSINESS DI

INVOICE DATE RANGE: 1/01/1998 THRU 99/99/9999

PAY DATE RANGE: 12/08/2021 THRU 12/21/2021

BUDGET TO USE: CB-CURRENT BUDGET

VENDOR	NAME	ITEM #	G/L ACCOUNT	NAME	DESCRIPTION	CHECK #	AMOUNT
--------	------	--------	-------------	------	-------------	---------	--------

01-002962	LARSON ENTERPRISES	I-202112150813	154 5604-825	BUSINESS DIST:	SEPTEMBER SALES TAX	150827	3,312.59
-----------	--------------------	----------------	--------------	----------------	---------------------	--------	----------

						VENDOR 01-002962 TOTALS	3,312.59
--	--	--	--	--	--	-------------------------	----------

						DEPARTMENT 604 BROADWAY EAST BUSINESS DI	TOTAL: 3,312.59
--	--	--	--	--	--	--	-----------------

						VENDOR SET 154 BROADWAY EAST BUS DIST	TOTAL: 3,312.59
--	--	--	--	--	--	---------------------------------------	-----------------

VENDOR SET: 01 CITY OF MATTOON

BANK: APBNK

FUND : 211 WATER FUND

DEPARTMENT: 351 RESERVOIRS & WTR SOURCES

INVOICE DATE RANGE: 1/01/1998 THRU 99/99/9999

PAY DATE RANGE: 12/08/2021 THRU 12/21/2021

BUDGET TO USE: CB-CURRENT BUDGET

VENDOR	NAME	ITEM #	G/L ACCOUNT	NAME	DESCRIPTION	CHECK #	AMOUNT
01-002194	IL POWER MARKETING DBA	I-1461321111	211 5351-321	NATURAL GAS &	LAKE PARADISE SHED	150813	6.10
						VENDOR 01-002194 TOTALS	6.10
						DEPARTMENT 351 RESERVOIRS & WTR SOURCES TOTAL:	6.10
01-001070	AMEREN ILLINOIS	I-202112100754	211 5353-321	NATURAL GAS &	2800 E LAKE PARADISE	003931	833.38
01-001070	AMEREN ILLINOIS	I-202112150800	211 5353-321	NATURAL GAS &	LAKE MATT PUMP	150754	70.27
						VENDOR 01-001070 TOTALS	903.65
01-002194	IL POWER MARKETING DBA	I-1461321111	211 5353-321	NATURAL GAS &	LAKE MATTOON PUMP	150813	56.22
01-002194	IL POWER MARKETING DBA	I-1461321111	211 5353-321	NATURAL GAS &	E LAKE PUMP HOUSE	150813	1,044.83
						VENDOR 01-002194 TOTALS	1,101.05
01-002411	DAVE BASHAM	I-DEC2021-CELLDB	211 5353-533	CELLULAR PHON:	CELL PHONE	000282	50.00
						VENDOR 01-002411 TOTALS	50.00
01-002806	SUDKAMP PLUMBING, HEAT	I-38857	211 5353-433	REPAIR OF MAC:	REPAIR VALVE	150863	293.13
01-002806	SUDKAMP PLUMBING, HEAT	I-38858	211 5353-433	REPAIR OF MAC:	REPAIR VALVE	150863	1,747.35
						VENDOR 01-002806 TOTALS	2,040.48
01-003097	CINTAS	I-4101963930	211 5353-439	OTHER REPAIR :	MOPS,MATS	150771	34.71
01-003097	CINTAS	I-4102776886	211 5353-439	OTHER REPAIR :	TOWELS,MATS	150771	34.71
01-003097	CINTAS	I-4103297025	211 5353-439	OTHER REPAIR :	TOWELS,MATS,MOP	150771	34.71
						VENDOR 01-003097 TOTALS	104.13
01-003690	MATHESON TRI-GAS, INC.	I-0024687750	211 5353-319	MISCELLANEOUS:	CARBON DIOXIDE	150829	2,038.14
						VENDOR 01-003690 TOTALS	2,038.14
01-003953	AMAZON CAPITAL SERVICE	I-1F9N-JGKQ-JL6W	211 5353-312	CLEANING SUPP:	BATTERIES, PAPER,FIL	150714	94.50
						VENDOR 01-003953 TOTALS	94.50

VENDOR SET: 01 CITY OF MATTOON

BANK: APBNK

FUND : 211 WATER FUND

DEPARTMENT: 353 WATER TREATMENT PLANT

INVOICE DATE RANGE: 1/01/1998 THRU 99/99/9999

PAY DATE RANGE: 12/08/2021 THRU 12/21/2021

BUDGET TO USE: CB-CURRENT BUDGET

VENDOR	NAME	ITEM #	G/L ACCOUNT	NAME	DESCRIPTION	CHECK #	AMOUNT
01-023800	CONSOLIDATED COMMUNICA	I-202112100767	211 5353-532	TELEPHONE	: 234-2454	003943	178.20
VENDOR 01-023800 TOTALS							178.20
01-037976	PDC LABORATORIES, INC.	I-I9490068	211 5353-519	OTHER PROFESS:	DISINFECTANT	150847	400.00
01-037976	PDC LABORATORIES, INC.	I-I9490088	211 5353-519	OTHER PROFESS:	PDC LABORATORIES, IN	150847	160.00
01-037976	PDC LABORATORIES, INC.	I-I9490206	211 5353-519	OTHER PROFESS:	PDC LABORATORIES, IN	150847	80.00
VENDOR 01-037976 TOTALS							640.00
01-038375	DAN PILSON AUTO CENTER	I-683526S	211 5353-434	REPAIR OF VEH:	FORD F150 REPAIRS	150786	85.85
VENDOR 01-038375 TOTALS							85.85
01-045171	USA BLUEBOOK	I-713876	211 5353-319	MISCELLANEOUS:	CHLORINE REAGENT SET	150873	1,332.34
01-045171	USA BLUEBOOK	I-714174	211 5353-319	MISCELLANEOUS:	CHLORINE REAGENT SET	150873	193.95
01-045171	USA BLUEBOOK	I-714175	211 5353-319	MISCELLANEOUS:	CHLORINE REAGENT SET	150873	323.25
01-045171	USA BLUEBOOK	I-720052	211 5353-377	PLANT EQUIPME:	PIPE NIPPLES	150873	25.49
01-045171	USA BLUEBOOK	I-727424	211 5353-377	PLANT EQUIPME:	DIGITAL CONTROLLER	150873	2,272.00
01-045171	USA BLUEBOOK	I-761576	211 5353-319	MISCELLANEOUS:	AMMONIA REAGENT, SOLU	150873	840.26
01-045171	USA BLUEBOOK	I-766573	211 5353-319	MISCELLANEOUS:	SAMPLES	150873	84.90
01-045171	USA BLUEBOOK	I-787963	211 5353-319	MISCELLANEOUS:	SAMPLES, CARTRIDGES, P	150873	765.85
VENDOR 01-045171 TOTALS							5,838.04

DEPARTMENT 353 WATER TREATMENT PLANT TOTAL: 13,074.04

01-000117	FULLER-WENTE INC	I-10942	211 5354-519	OTHER PROFESS:	LEAK REPAIR @ 90 PRA	150798	1,635.00
01-000117	FULLER-WENTE INC	I-202112150810	211 5354-730	IMPROVEMENTS :	2021 HYDRANT REPLACE	150798	14,667.56
VENDOR 01-000117 TOTALS							16,302.56
01-000755	ALTORFER	I-V2286802	211 5354-440	RENTALS	: EQUIPMENT RENTAL	150753	3,406.83
VENDOR 01-000755 TOTALS							3,406.83
01-001070	AMEREN ILLINOIS	I-202112100751	211 5354-321	NATURAL GAS &:	RR2, SHED	003928	33.69
01-001070	AMEREN ILLINOIS	I-202112150800	211 5354-321	NATURAL GAS &:	12TH ST POWER	150754	121.06
01-001070	AMEREN ILLINOIS	I-202112150800	211 5354-321	NATURAL GAS &:	W 121 WATER TWR	150754	29.46

VENDOR SET: 01 CITY OF MATTOON

BANK: APBNK

FUND : 211 WATER FUND

DEPARTMENT: 354 WATER DISTRIBUTION

INVOICE DATE RANGE: 1/01/1998 THRU 99/99/9999

PAY DATE RANGE: 12/08/2021 THRU 12/21/2021

BUDGET TO USE: CB-CURRENT BUDGET

VENDOR	NAME	ITEM #	G/L ACCOUNT	NAME	DESCRIPTION	CHECK #	AMOUNT
01-001070	AMEREN ILLINOIS	I-202112150800	211 5354-321	NATURAL GAS &	EAST WATER TWR	150754	29.97
01-001070	AMEREN ILLINOIS	I-202112150800	211 5354-321	NATURAL GAS &	12TH ST STORAGE	150754	30.07
						VENDOR 01-001070 TOTALS	244.25
01-001213	DIESEL SPEED REPAIR, I	I-19165	211 5354-434	REPAIR OF VEH:	REPLACE SUSPENSION	150790	50.03
01-001213	DIESEL SPEED REPAIR, I	I-19186	211 5354-434	REPAIR OF VEH:	INSPECT, TRANSMISSIO	150790	85.56
01-001213	DIESEL SPEED REPAIR, I	I-19194	211 5354-434	REPAIR OF VEH:	REPAIR LIGHTS	150790	12.51
						VENDOR 01-001213 TOTALS	148.10
01-001331	OWEN MOTOR SPORTS INC.	I-50080642	211 5354-318	VEHICLE PARTS:	WASH 2021 KAWASAKI	150844	16.63
						VENDOR 01-001331 TOTALS	16.63
01-001787	BROWN'S AUTO SALES OF	I-784	211 5354-434	REPAIR OF VEH:	UNIT 501 REPAIRS	150763	67.49
						VENDOR 01-001787 TOTALS	67.49
01-002194	IL POWER MARKETING DBA	I-1461321111	211 5354-321	NATURAL GAS &	12TH ST PUMP	150813	34.17
01-002194	IL POWER MARKETING DBA	I-1461321111	211 5354-321	NATURAL GAS &	1201 MARSHALL AVE	150813	131.74
01-002194	IL POWER MARKETING DBA	I-1461321111	211 5354-321	NATURAL GAS &	3919 DEWITT	150813	2.93
01-002194	IL POWER MARKETING DBA	I-1461321111	211 5354-321	NATURAL GAS &	SWORDS STANDPIPE	150813	15.90
01-002194	IL POWER MARKETING DBA	I-1461321111	211 5354-321	NATURAL GAS &	EAST TOWER DIVISION	150813	3.27
01-002194	IL POWER MARKETING DBA	I-1461321111	211 5354-321	NATURAL GAS &	401 DEWITT AVE EAST	150813	66.25
01-002194	IL POWER MARKETING DBA	I-1461321111	211 5354-321	NATURAL GAS &	621 S 12TH	150813	15.43
01-002194	IL POWER MARKETING DBA	I-1461321111	211 5354-321	NATURAL GAS &	S 12TH ST	150813	11.21
01-002194	IL POWER MARKETING DBA	I-1461321111	211 5354-321	NATURAL GAS &	1201 MARSHALL	150813	5.44
01-002194	IL POWER MARKETING DBA	I-1461321111	211 5354-321	NATURAL GAS &	12TH ST LIGHTING	150813	3.64
						VENDOR 01-002194 TOTALS	289.98
01-002429	SHIRLEY UTILITY CONSTR	I-2021085	211 5354-519	OTHER PROFESS:	BORE IN WATER SERVIC	150856	3,000.00
						VENDOR 01-002429 TOTALS	3,000.00
01-002541	MLB OUTDOOR PRODUCTS	I-49790	211 5354-316	TOOLS & EQUIP:	REMOVE CARB & CLEAN	150838	28.00
01-002541	MLB OUTDOOR PRODUCTS	I-49880	211 5354-316	TOOLS & EQUIP:	SHARPEN CHAIN SAW	150838	65.17
						VENDOR 01-002541 TOTALS	93.17

VENDOR SET: 01 CITY OF MATTOON

BANK: APBNK

FUND : 211 WATER FUND

DEPARTMENT: 354 WATER DISTRIBUTION

INVOICE DATE RANGE: 1/01/1998 THRU 99/99/9999

PAY DATE RANGE: 12/08/2021 THRU 12/21/2021

BUDGET TO USE: CB-CURRENT BUDGET

VENDOR	NAME	ITEM #	G/L ACCOUNT	NAME	DESCRIPTION	CHECK #	AMOUNT
01-002990	CINTAS	I-5085407566	211 5354-313	MEDICAL & SAF:	MEDICAL SUPPLIES	150770	31.93
						VENDOR 01-002990 TOTALS	31.93
01-003095	ADVANCE AUTO PARTS	I-202112160824	211 5354-316	TOOLS & EQUIP:	COUPLER,BRAKE FLUID	150750	11.34
01-003095	ADVANCE AUTO PARTS	I-202112160824	211 5354-318	VEHICLE PARTS:	COUPLER,BRAKE FLUID	150750	52.54
						VENDOR 01-003095 TOTALS	63.88
01-003206	BIRKEYS	I-P33478	211 5354-316	TOOLS & EQUIP:	BIRKEYS	150761	11.33
01-003206	BIRKEYS	I-W30616	211 5354-318	VEHICLE PARTS:	TRASH PUMP REPAIRS	150761	23.27
01-003206	BIRKEYS	I-W30640	211 5354-318	VEHICLE PARTS:	TRASH PUMP REPAIRS	150761	30.50
						VENDOR 01-003206 TOTALS	65.10
01-003488	SSC SERVICES, INC.	I-8298	211 5354-460	OTHER PROPRT:	JANITORIAL SERVICES	150861	233.33
						VENDOR 01-003488 TOTALS	233.33
01-003646	SCHEFF'S OFFICE SUPPLI	I-2169	211 5354-311	OFFICE SUPPLI:	OFFICE SUPPLIES	150855	33.12
01-003646	SCHEFF'S OFFICE SUPPLI	I-2215	211 5354-311	OFFICE SUPPLI:	WALL CALENDAR	150855	7.32
						VENDOR 01-003646 TOTALS	40.44
01-003660	TRUeline COMMUNICATION	I-T1411	211 5354-433	REPAIR OF MAC:	INSTALL RADIO IN TRU	150868	267.67
						VENDOR 01-003660 TOTALS	267.67
01-003762	XEROX FINANCIAL SERVIC	I-2969997	211 5354-814	PRINTING/COPY:	LEASE & USE	150880	41.79
						VENDOR 01-003762 TOTALS	41.79
01-003865	ALEX FUQUA	I-DEC2021-CELLAF	211 5354-533	CELL PHONES :	CELL PHONE	150799	16.67
						VENDOR 01-003865 TOTALS	16.67
01-003947	PROGRESSIVE CHEMICAL &	I-51676	211 5354-316	TOOLS & EQUIP:	STRIPE-INVERTED MARK	150850	188.88
						VENDOR 01-003947 TOTALS	188.88

VENDOR SET: 01 CITY OF MATTOON

BANK: APBNK

FUND : 211 WATER FUND

DEPARTMENT: 354 WATER DISTRIBUTION

INVOICE DATE RANGE: 1/01/1998 THRU 99/99/9999

PAY DATE RANGE: 12/08/2021 THRU 12/21/2021

BUDGET TO USE: CB-CURRENT BUDGET

VENDOR	NAME	ITEM #	G/L ACCOUNT	NAME	DESCRIPTION	CHECK #	AMOUNT
01-004298	WM CORPORATE SERVICES,	I-0000187-4072-0	211 5354-460	OTHER PROPERT:	TRASH SERVICES	003984	41.47
					VENDOR 01-004298	TOTALS	41.47
01-004910	BRIAN BUTLER	I-202112150802	211 5354-313	MEDICAL & SAF:	REIMBURSE BOOTS	150765	25.00
					VENDOR 01-004910	TOTALS	25.00
01-012025	DETECTION SECURITY CO	I-178059	211 5354-432	REPAIR OF STR:	ALARM MONITORING	150789	96.00
					VENDOR 01-012025	TOTALS	96.00
01-016000	JOHN DEERE FINANCIAL	I-202112160829	211 5354-316	TOOLS & EQUIP:	RATCHETING TIES	150819	11.00
01-016000	JOHN DEERE FINANCIAL	I-202112160829	211 5354-316	TOOLS & EQUIP:	FUEL CAN	150819	7.00
					VENDOR 01-016000	TOTALS	18.00
01-020607	KEVIN HAMILTON	I-DEC2021-CELLKH	211 5354-533	CELL PHONES :	CELL PHONE	150804	16.67
					VENDOR 01-020607	TOTALS	16.67
01-021402	3 SISTERS LOGISTICS, L	I-79218	211 5354-376	BACKFILL & SU:	FILLSAND	150749	285.09
					VENDOR 01-021402	TOTALS	285.09
01-023800	CONSOLIDATED COMMUNICA	I-202112100762	211 5354-532	TELEPHONE :	235-5460	003938	178.82
					VENDOR 01-023800	TOTALS	178.82
01-025600	ILMO PRODUCTS COMPANY	I-01249718	211 5354-440	RENTALS :	CYLINDER RENTAL	150814	8.80
					VENDOR 01-025600	TOTALS	8.80
01-030000	KULL LUMBER CO	I-202112160820	211 5354-316	TOOLS & EQUIP:	TAPE MEASURES	150821	14.82
					VENDOR 01-030000	TOTALS	14.82

VENDOR SET: 01 CITY OF MATTOON

BANK: APBNK

FUND : 211 WATER FUND

DEPARTMENT: 354 WATER DISTRIBUTION

INVOICE DATE RANGE: 1/01/1998 THRU 99/99/9999

PAY DATE RANGE: 12/08/2021 THRU 12/21/2021

BUDGET TO USE: CB-CURRENT BUDGET

VENDOR	NAME	ITEM #	G/L ACCOUNT	NAME	DESCRIPTION	CHECK #	AMOUNT
01-030083	LANMAN OIL CO INC	I-472118	211 5354-326	FUEL	: GAS	150826	4.00
					VENDOR 01-030083 TOTALS		4.00
01-031000	LORENZ SUPPLY CO.	I-565141	211 5354-311	OFFICE SUPPLI:	LINERS,TOWELS	150828	91.98
					VENDOR 01-031000 TOTALS		91.98
01-033200	MATTOON PRINTING CENTE	I-202112160823	211 5354-375	LEAK REPAIR M:	DOOR HANGERS	150833	2,201.30
					VENDOR 01-033200 TOTALS		2,201.30
01-033800	MATTOON WATER DEPT	I-202112160830	211 5354-321	NATURAL GAS &:	401 DEWITT	003978	31.22
					VENDOR 01-033800 TOTALS		31.22
01-035154	MID-ILLINOIS CONCRETE	I-241461	211 5354-376	BACKFILL & SU:	HOT PATCH	150835	845.00
					VENDOR 01-035154 TOTALS		845.00
01-036810	C.R. NEFF PLUMBING, HE	I-52273	211 5354-519	OTHER PROFESS:	REPLACED VALVE	150766	176.36
					VENDOR 01-036810 TOTALS		176.36
01-038300	PERRY'S LOCKSMITH	I-33-78391	211 5354-311	OFFICE SUPPLI:	KEYS	150848	23.33
					VENDOR 01-038300 TOTALS		23.33
01-039600	NEAL TIRE & AUTO SERVI	I-202112160825	211 5354-433	REPAIR OF MAC:	TIRES	150842	1,491.61
					VENDOR 01-039600 TOTALS		1,491.61
01-040467	SAFETY COMPLIANCE	I-34466	211 5354-313	MEDICAL & SAF:	TIE BACK RINGS	150853	13.33
01-040467	SAFETY COMPLIANCE	I-34470	211 5354-313	MEDICAL & SAF:	GLOVES	150853	15.71
01-040467	SAFETY COMPLIANCE	I-34490	211 5354-313	MEDICAL & SAF:	CONSTRUCTION HARNESS	150853	40.00
					VENDOR 01-040467 TOTALS		69.04

VENDOR SET: 01 CITY OF MATTOON

BANK: APBNK

FUND : 211 WATER FUND

DEPARTMENT: 354 WATER DISTRIBUTION

INVOICE DATE RANGE: 1/01/1998 THRU 99/99/9999

PAY DATE RANGE: 12/08/2021 THRU 12/21/2021

BUDGET TO USE: CB-CURRENT BUDGET

VENDOR	NAME	ITEM #	G/L ACCOUNT	NAME	DESCRIPTION	CHECK #	AMOUNT
01-044325	TERMINIX	I-570623	211 5354-460	OTHER PROPERT:	PEST CONTROL	150864	31.67
						VENDOR 01-044325 TOTALS	31.67
						DEPARTMENT 354 WATER DISTRIBUTION TOTAL:	30,168.88
01-000090	MIDWEST MAILING &	I-P107801	211 5355-815	POSTAGE METER:	MAINTENANCE AGREEMEN	150837	409.00
01-000090	MIDWEST MAILING &	I-SI81226	211 5355-815	POSTAGE METER:	INK CARTRIDGE	150837	83.15
						VENDOR 01-000090 TOTALS	492.15
01-000720	CARDMEMBER SERVICES	I-202112160828	211 5355-516	TECHNOLOGY SU:	TAX & ACCOUNTING PRO	150768	141.67
						VENDOR 01-000720 TOTALS	141.67
01-001657	TYLER TECHNOLOGIES	I-025-360211	211 5355-516	TECHNOLOGY SU:	BEACON METER READING	150870	97.50
						VENDOR 01-001657 TOTALS	97.50
01-001663	ADVANCED DIGITAL SOLUT	I-IN35868	211 5355-814	PRINTING/COPY:	XEROX B8045	150751	10.29
01-001663	ADVANCED DIGITAL SOLUT	I-IN35983	211 5355-814	PRINTING/COPY:	XEROX 3330	150751	11.82
						VENDOR 01-001663 TOTALS	22.11
01-002603	MIDWEST CREDIT & COLLE	I-010009242111300000	211 5355-579	COLLECTION FE:	WATER/SEWER COLLECTI	150836	173.40
						VENDOR 01-002603 TOTALS	173.40
01-002655	MULTI-PRINT SOLUTIONS	I-3159	211 5355-311	OFFICE SUPPLI:	ENVELOPES	150840	330.50
						VENDOR 01-002655 TOTALS	330.50
01-003328	DOEHRING, WINDERS & CO	I-202112150812	211 5355-513	AUDITING SERV:	AUDITING SERVICES	150791	18,000.00
						VENDOR 01-003328 TOTALS	18,000.00
01-003490	INFOSEND, INC.	I-202946	211 5355-531	POSTAGE	: WATER/SEWER BILL PRI	150818	1,083.08

VENDOR SET: 01 CITY OF MATTOON

BANK: APBNK

FUND : 211 WATER FUND

DEPARTMENT: 355 ACCOUNTING & COLLECTION

INVOICE DATE RANGE: 1/01/1998 THRU 99/99/9999

PAY DATE RANGE: 12/08/2021 THRU 12/21/2021

BUDGET TO USE: CB-CURRENT BUDGET

VENDOR	NAME	ITEM #	G/L ACCOUNT	NAME	DESCRIPTION	CHECK #	AMOUNT
01-003490	INFOSEND, INC.	I-202946	211 5355-519	OTHER PROFESS:	WATER/SEWER BILL PRI	150818	295.94
					VENDOR 01-003490	TOTALS	1,379.02
01-003527	INB	I-202112160822	211 5355-811	BANK SERVICE :	EPAY FEES 11/2021	150815	7.43
					VENDOR 01-003527	TOTALS	7.43
01-003762	XEROX FINANCIAL SERVIC	I-2940402	211 5355-814	PRINTING/COPY:	LEASE PAYMENT	150879	64.74
					VENDOR 01-003762	TOTALS	64.74
01-003880	NCR PAYMENT SOLUTIONS	I-202112150797	211 5355-811	BANK SERVICE :	EPAY FEES 11/2021	003979	1,332.31
					VENDOR 01-003880	TOTALS	1,332.31
01-004290	TYLER BUSINESS FORMS	I-65749	211 5355-311	OFFICE SUPPLI:	TAX FORMS	150869	39.74
					VENDOR 01-004290	TOTALS	39.74
01-017400	TSYS	I-202112150807	211 5355-811	BANK SERVICE :	FINANCE 12/2021 CC F	003982	160.40
					VENDOR 01-017400	TOTALS	160.40
01-023500	MOTION INDUSTRIES, INC	I-IL64-029157	211 5355-319	MISCELLANEOUS:	FLAGS	150839	288.44
					VENDOR 01-023500	TOTALS	288.44
01-023800	CONSOLIDATED COMMUNICA	I-202112100766	211 5355-532	TELEPHONE :	235-5483	003942	160.73
					VENDOR 01-023800	TOTALS	160.73
01-043522	STAPLES CREDIT PLAN	I-202112150817	211 5355-311	OFFICE SUPPLI:	OFFICE SUPPLIES	150862	44.17
					VENDOR 01-043522	TOTALS	44.17

DEPARTMENT 355 ACCOUNTING & COLLECTION TOTAL: 22,734.31

VENDOR SET: 01 CITY OF MATTOON

BANK: APBNK

FUND : 211 WATER FUND

DEPARTMENT: 356 ADMINISTRATIVE & GENERAL

INVOICE DATE RANGE: 1/01/1998 THRU 99/99/9999

PAY DATE RANGE: 12/08/2021 THRU 12/21/2021

BUDGET TO USE: CB-CURRENT BUDGET

VENDOR	NAME	ITEM #	G/L ACCOUNT	NAME	DESCRIPTION	CHECK #	AMOUNT
01-002602	DEAN BARBER	I-DEC2021-CELLDB	211 5356-533	CELLULAR PHON:	CELL PHONE	000283	33.33
VENDOR 01-002602 TOTALS							33.33
01-003488	SSC SERVICES, INC.	I-8300	211 5356-460	OTHER PROPRT:	JANITORIAL SERVICES	150861	66.00
01-003488	SSC SERVICES, INC.	I-8304	211 5356-460	OTHER PROPRT:	JANITORIAL SERVICES	150861	66.00
VENDOR 01-003488 TOTALS							132.00
01-003762	XEROX FINANCIAL SERVIC	I-2969997	211 5356-814	PRINT/COPY MA:	LEASE & USE	150880	70.21
VENDOR 01-003762 TOTALS							70.21
01-016000	JOHN DEERE FINANCIAL	I-202112160829	211 5356-319	MISCELLANEOUS:	JACKET,OVERALLS	150819	26.66
VENDOR 01-016000 TOTALS							26.66

DEPARTMENT 356 ADMINISTRATIVE & GENERAL TOTAL: 262.20

VENDOR SET 211 WATER FUND TOTAL: 66,245.53

VENDOR SET: 01 CITY OF MATTOON

BANK: APBNK

FUND : 212 SEWER FUND

DEPARTMENT: 342 SEWER COLLECTION SYSTEM

INVOICE DATE RANGE: 1/01/1998 THRU 99/99/9999

PAY DATE RANGE: 12/08/2021 THRU 12/21/2021

BUDGET TO USE: CB-CURRENT BUDGET

VENDOR	NAME	ITEM #	G/L ACCOUNT	NAME	DESCRIPTION	CHECK #	AMOUNT
01-000755	ALTORFER	I-V2286802	212 5342-440	RENTALS	: EQUIPMENT RENTAL	150753	3,406.84
						VENDOR 01-000755 TOTALS	3,406.84
01-001213	DIESEL SPEED REPAIR, I	I-19165	212 5342-434	REPAIR OF VEH:	REPLACE SUSPENSION	150790	50.04
01-001213	DIESEL SPEED REPAIR, I	I-19186	212 5342-434	REPAIR OF VEH:	INSPECT, TRANSMISSIO	150790	85.56
01-001213	DIESEL SPEED REPAIR, I	I-19194	212 5342-434	REPAIR OF VEH:	REPAIR LIGHTS	150790	12.51
						VENDOR 01-001213 TOTALS	148.11
01-001331	OWEN MOTOR SPORTS INC.	I-50080642	212 5342-318	VEHICLE PARTS:	WASH 2021 KAWASAKI	150844	16.63
						VENDOR 01-001331 TOTALS	16.63
01-001787	BROWN'S AUTO SALES OF	I-784	212 5342-434	REPAIR OF VEH:	UNIT 501 REPAIRS	150763	67.49
						VENDOR 01-001787 TOTALS	67.49
01-002194	IL POWER MARKETING DBA	I-1461321111	212 5342-321	UTILITIES	: 401 DEWITT AVE EAST	150813	66.25
						VENDOR 01-002194 TOTALS	66.25
01-002541	MLB OUTDOOR PRODUCTS	I-49790	212 5342-316	TOOLS & EQUIP:	REMOVE CARB & CLEAN	150838	28.00
01-002541	MLB OUTDOOR PRODUCTS	I-49880	212 5342-316	TOOLS & EQUIP:	SHARPEN CHAIN SAW	150838	65.17
						VENDOR 01-002541 TOTALS	93.17
01-002879	IL CENTRAL RAILROAD	I-9500231359	212 5342-440	RENTALS	: SAN SEWER PERMIT	150809	250.00
						VENDOR 01-002879 TOTALS	250.00
01-002990	CINTAS	I-5085407566	212 5342-313	MEDICAL & SAF:	MEDICAL SUPPLIES	150770	31.93
						VENDOR 01-002990 TOTALS	31.93
01-003095	ADVANCE AUTO PARTS	I-202112160824	212 5342-316	TOOLS & EQUIP:	COUPLER,BRAKE FLUID	150750	11.34
01-003095	ADVANCE AUTO PARTS	I-202112160824	212 5342-318	VEHICLE PARTS:	COUPLER,BRAKE FLUID	150750	52.54
						VENDOR 01-003095 TOTALS	63.88

VENDOR SET: 01 CITY OF MATTOON

BANK: APBNK

FUND : 212 SEWER FUND

DEPARTMENT: 342 SEWER COLLECTION SYSTEM

INVOICE DATE RANGE: 1/01/1998 THRU 99/99/9999

PAY DATE RANGE: 12/08/2021 THRU 12/21/2021

BUDGET TO USE: CB-CURRENT BUDGET

VENDOR	NAME	ITEM #	G/L ACCOUNT	NAME	DESCRIPTION	CHECK #	AMOUNT
01-003206	BIRKEYS	I-P33478	212 5342-316	TOOLS & EQUIP:	BIRKEYS	150761	11.33
01-003206	BIRKEYS	I-W30616	212 5342-318	VEHICLE PARTS:	TRASH PUMP REPAIRS	150761	23.27
01-003206	BIRKEYS	I-W30640	212 5342-318	VEHICLE PARTS:	TRASH PUMP REPAIRS	150761	30.50
						VENDOR 01-003206 TOTALS	65.10
01-003488	SSC SERVICES, INC.	I-8298	212 5342-460	OTHER PROPERT:	JANITORIAL SERVICES	150861	233.34
						VENDOR 01-003488 TOTALS	233.34
01-003646	SCHEFF'S OFFICE SUPPLI	I-2169	212 5342-311	OFFICE SUPPLI:	OFFICE SUPPLIES	150855	33.12
01-003646	SCHEFF'S OFFICE SUPPLI	I-2215	212 5342-311	OFFICE SUPPLI:	WALL CALENDAR	150855	7.33
						VENDOR 01-003646 TOTALS	40.45
01-003660	TRUELINE COMMUNICATION	I-T1411	212 5342-433	REPAIR OF MAC:	INSTALL RADIO IN TRU	150868	267.67
						VENDOR 01-003660 TOTALS	267.67
01-003762	XEROX FINANCIAL SERVIC	I-2969997	212 5342-814	PRINTING/COPY:	LEASE & USE	150880	41.79
						VENDOR 01-003762 TOTALS	41.79
01-003865	ALEX FUQUA	I-DEC2021-CELLAF	212 5342-533	CELL PHONES :	CELL PHONE	150799	16.67
						VENDOR 01-003865 TOTALS	16.67
01-003947	PROGRESSIVE CHEMICAL &	I-51676	212 5342-316	TOOLS & EQUIP:	STRIPE-INVERTED MARK	150850	188.89
						VENDOR 01-003947 TOTALS	188.89
01-004298	WM CORPORATE SERVICES,	I-0000187-4072-0	212 5342-460	OTHER PROPERT:	TRASH SERVICES	003984	41.48
						VENDOR 01-004298 TOTALS	41.48
01-004309	IL CENTRAL RAILROAD	I-850113138	212 5342-439	OTHER REPAIR :	CNRR SAN SEWER REPAI	150810	13,579.49
						VENDOR 01-004309 TOTALS	13,579.49

VENDOR SET: 01 CITY OF MATTOON

BANK: APBNK

FUND : 212 SEWER FUND

DEPARTMENT: 342 SEWER COLLECTION SYSTEM

INVOICE DATE RANGE: 1/01/1998 THRU 99/99/9999

PAY DATE RANGE: 12/08/2021 THRU 12/21/2021

BUDGET TO USE: CB-CURRENT BUDGET

VENDOR	NAME	ITEM #	G/L ACCOUNT	NAME	DESCRIPTION	CHECK #	AMOUNT
01-004910	BRIAN BUTLER	I-202112150802	212 5342-313	MEDICAL & SAF:	REIMBURSE BOOTS	150765	25.00
					VENDOR 01-004910 TOTALS		25.00
01-007820	COE EQUIPMENT INC	I-77615	212 5342-318	VEHICLE PARTS:	VACTOR REPAIRS	150774	14,181.66
					VENDOR 01-007820 TOTALS		14,181.66
01-012025	DETECTION SECURITY CO	I-178059	212 5342-432	REPAIR OF STR:	ALARM MONITORING	150789	96.00
					VENDOR 01-012025 TOTALS		96.00
01-016000	JOHN DEERE FINANCIAL	I-202112160829	212 5342-316	TOOLS & EQUIP:	RATCHETING TIES	150819	11.00
01-016000	JOHN DEERE FINANCIAL	I-202112160829	212 5342-316	TOOLS & EQUIP:	FUEL CAN	150819	7.00
					VENDOR 01-016000 TOTALS		18.00
01-020607	KEVIN HAMILTON	I-DEC2021-CELLKH	212 5342-533	CELL PHONES :	CELL PHONE	150804	16.66
					VENDOR 01-020607 TOTALS		16.66
01-023800	CONSOLIDATED COMMUNICA	I-202112100762	212 5342-532	TELEPHONE :	235-5460	003938	178.81
					VENDOR 01-023800 TOTALS		178.81
01-025600	ILMO PRODUCTS COMPANY	I-01249718	212 5342-440	RENTALS :	CYLINDER RENTAL	150814	8.80
					VENDOR 01-025600 TOTALS		8.80
01-030000	KULL LUMBER CO	I-202112160820	212 5342-316	TOOLS & EQUIP:	TAPE MEASURES	150821	14.82
01-030000	KULL LUMBER CO	I-202112160820	212 5342-363	BACKFILL & SU:	CONCRETE MIX	150821	35.94
					VENDOR 01-030000 TOTALS		50.76
01-030083	LANMAN OIL CO INC	I-472118	212 5342-326	FUEL :	GAS	150826	4.00
					VENDOR 01-030083 TOTALS		4.00

VENDOR SET: 01 CITY OF MATTOON

BANK: APBNK

FUND : 212 SEWER FUND

DEPARTMENT: 342 SEWER COLLECTION SYSTEM

INVOICE DATE RANGE: 1/01/1998 THRU 99/99/9999

PAY DATE RANGE: 12/08/2021 THRU 12/21/2021

BUDGET TO USE: CB-CURRENT BUDGET

VENDOR	NAME	ITEM #	G/L ACCOUNT	NAME	DESCRIPTION	CHECK #	AMOUNT
01-031000	LORENZ SUPPLY CO.	I-565141	212 5342-311	OFFICE SUPPLI:	LINERS,TOWELS	150828	91.99
					VENDOR 01-031000	TOTALS	91.99
01-033800	MATTOON WATER DEPT	I-202112160830	212 5342-321	UTILITIES	: 401 DEWITT	003978	31.23
					VENDOR 01-033800	TOTALS	31.23
01-035154	MID-ILLINOIS CONCRETE	I-242415	212 5342-363	BACKFILL & SU:	2820 CHAMPAIGN	150835	1,089.00
01-035154	MID-ILLINOIS CONCRETE	I-242743	212 5342-363	BACKFILL & SU:	WESTERN & PARK	150835	1,694.00
01-035154	MID-ILLINOIS CONCRETE	I-243011	212 5342-363	BACKFILL & SU:	WESTERN & PARK	150835	423.50
01-035154	MID-ILLINOIS CONCRETE	I-243012	212 5342-363	BACKFILL & SU:	13TH & MOULTRIE	150835	196.00
					VENDOR 01-035154	TOTALS	3,402.50
01-038300	PERRY'S LOCKSMITH	I-33-78391	212 5342-311	OFFICE SUPPLI:	KEYS	150848	23.34
					VENDOR 01-038300	TOTALS	23.34
01-039600	NEAL TIRE & AUTO SERVI	I-202112160825	212 5342-433	REPAIR OF MAC:	TIRES	150842	1,491.61
					VENDOR 01-039600	TOTALS	1,491.61
01-040467	SAFETY COMPLIANCE	I-34466	212 5342-313	MEDICAL & SAF:	TIE BACK RINGS	150853	13.34
01-040467	SAFETY COMPLIANCE	I-34470	212 5342-313	MEDICAL & SAF:	GLOVES	150853	15.73
01-040467	SAFETY COMPLIANCE	I-34490	212 5342-313	MEDICAL & SAF:	CONSTRUCTION HARNESS	150853	40.00
					VENDOR 01-040467	TOTALS	69.07
01-044325	TERMINIX	I-570623	212 5342-460	OTHER PROPERT:	PEST CONTROL	150864	31.67
					VENDOR 01-044325	TOTALS	31.67
DEPARTMENT 342 SEWER COLLECTION SYSTEM						TOTAL:	38,340.28
01-001070	AMEREN ILLINOIS	I-202112100750	212 5343-321	NATURAL GAS &:	4220 DEWITT LIFT STA	003927	36.82
					VENDOR 01-001070	TOTALS	36.82

VENDOR SET: 01 CITY OF MATTOON

BANK: APBNK

FUND : 212 SEWER FUND

DEPARTMENT: 343 SEWER LIFT STATIONS

INVOICE DATE RANGE: 1/01/1998 THRU 99/99/9999

PAY DATE RANGE: 12/08/2021 THRU 12/21/2021

BUDGET TO USE: CB-CURRENT BUDGET

VENDOR	NAME	ITEM #	G/L ACCOUNT	NAME	DESCRIPTION	CHECK #	AMOUNT
01-002194	IL POWER MARKETING DBA I-1461321111		212 5343-321	NATURAL GAS &	11669 US HWY 45	150813	99.42
01-002194	IL POWER MARKETING DBA I-1461321111		212 5343-321	NATURAL GAS &	4220 DEWITT	150813	13.58
01-002194	IL POWER MARKETING DBA I-1461321111		212 5343-321	NATURAL GAS &	2521 N 6TH	150813	1,050.88
01-002194	IL POWER MARKETING DBA I-1461321111		212 5343-321	NATURAL GAS &	3601 OAK	150813	37.10
01-002194	IL POWER MARKETING DBA I-1461321111		212 5343-321	NATURAL GAS &	GARFIELD AVE	150813	47.84
01-002194	IL POWER MARKETING DBA I-1461321111		212 5343-321	NATURAL GAS &	206 MCFALL RD	150813	5.39
01-002194	IL POWER MARKETING DBA I-1461321111		212 5343-321	NATURAL GAS &	1503 N 19TH	150813	11.55

VENDOR 01-002194 TOTALS 1,265.76

DEPARTMENT 343 SEWER LIFT STATIONS TOTAL: 1,302.58

01-000598	CURRY CONSTRUCTION, IN I-202112150809		212 5344-730	IMPROVEMENTS : PRIMARY PUMP REPLACE	150784		27,832.50
							VENDOR 01-000598 TOTALS 27,832.50

01-000720	CARDMEMBER SERVICES I-202112160828		212 5344-366	PLANT MTCE & : BEARING KING	150768		155.38
01-000720	CARDMEMBER SERVICES I-202112160828		212 5344-562	TRAVEL & TRAI: IWEA	150768		15.00
01-000720	CARDMEMBER SERVICES I-202112160828		212 5344-562	TRAVEL & TRAI: IWEA	150768		30.00
01-000720	CARDMEMBER SERVICES I-202112160828		212 5344-562	TRAVEL & TRAI: IWEA	150768		60.00
01-000720	CARDMEMBER SERVICES I-202112160828		212 5344-562	TRAVEL & TRAI: AWWA	150768		36.00
01-000720	CARDMEMBER SERVICES I-202112160828		212 5344-311	OFFICE SUPPLI: VISTA PRINT	150768		30.81
01-000720	CARDMEMBER SERVICES I-202112160828		212 5344-516	TECHNOLOGY SU: LAST PASS	150768		64.00
01-000720	CARDMEMBER SERVICES I-202112160828		212 5344-316	TOOLS & EQUIP: OFFROAD ARMOR	150768		400.00
							VENDOR 01-000720 TOTALS 791.19

01-001070	AMEREN ILLINOIS I-202112100753		212 5344-321	NATURAL GAS &: S 12TH ST SHED	003930		27.22
							VENDOR 01-001070 TOTALS 27.22

01-002194	IL POWER MARKETING DBA I-1461321111		212 5344-321	NATURAL GAS &: 820 S 5TH PLACE	150813		10,122.60
							VENDOR 01-002194 TOTALS 10,122.60

01-002958	BATTERY SPECIALISTS, I I-185042		212 5344-366	PLANT MTCE & : BATTERY	150759		89.95
							VENDOR 01-002958 TOTALS 89.95

VENDOR SET: 01 CITY OF MATTOON

BANK: APBNK

FUND : 212 SEWER FUND

DEPARTMENT: 344 WASTEWATER TREATMNT PLANT

INVOICE DATE RANGE: 1/01/1998 THRU 99/99/9999

PAY DATE RANGE: 12/08/2021 THRU 12/21/2021

BUDGET TO USE: CB-CURRENT BUDGET

VENDOR	NAME	ITEM #	G/L ACCOUNT	NAME	DESCRIPTION	CHECK #	AMOUNT
01-003097	CINTAS	I-4100504610	212 5344-439	OTHER REPAIR :	MATS,TOWELS	150771	18.15
01-003097	CINTAS	I-4102599694	212 5344-439	OTHER REPAIR :	MATS,TOWELS	150771	18.15
01-003097	CINTAS	I-4103175672	212 5344-439	OTHER REPAIR :	MATS,TOWELS	150771	18.15
01-003097	CINTAS	I-4103827626	212 5344-439	OTHER REPAIR :	MATS,TOWELS	150771	18.15
01-003097	CINTAS	I-4104504629	212 5344-439	OTHER REPAIR :	MATS,TOWELS	150771	18.15
						VENDOR 01-003097 TOTALS	90.75
01-003762	XEROX FINANCIAL SERVIC	I-2969997	212 5344-814	COPY MACHINE :	LEASE & USE	150880	43.19
						VENDOR 01-003762 TOTALS	43.19
01-004298	WM CORPORATE SERVICES,	I-0005233-4072-7	212 5344-460	OTHER PROPERT:	SLUDGE DISPOSAL	003971	97.01
01-004298	WM CORPORATE SERVICES,	I-0007310-2754-6	212 5344-460	OTHER PROPERT:	SLUDGE DISPOSAL	003971	152.01
						VENDOR 01-004298 TOTALS	249.02
01-004306	TFORCE FREIGHT	I-32444767	212 5344-319	MISCELLANEOUS:	TFORCE FREIGHT	150865	356.97
						VENDOR 01-004306 TOTALS	356.97
01-004308	COGENT	I-5524723	212 5344-730	IMPROVEMENTS :	COGENT	150775	3,610.15
						VENDOR 01-004308 TOTALS	3,610.15
01-009093	CONNOR CO	I-S009820672.001	212 5344-366	PLANT MTCE & :	BREAKER KIT,CAP	150783	6.58
01-009093	CONNOR CO	I-S009821387.001	212 5344-366	PLANT MTCE & :	HANDLE REPAIR KIT	150783	3.99
						VENDOR 01-009093 TOTALS	10.57
01-019650	GRAINGER PARTS	I-9137119492	212 5344-366	PLANT MTCE & :	GRAINGER PARTS	150802	52.57
						VENDOR 01-019650 TOTALS	52.57
01-020540	HACH COMPANY	I-12765511	212 5344-319	MISCELLANEOUS:	HACH COMPANY	150803	94.18
						VENDOR 01-020540 TOTALS	94.18

DEPARTMENT 344 WASTEWATER TREATMNT PLANTTOTAL: 43,370.86

VENDOR SET: 01 CITY OF MATTOON

BANK: APBNK

FUND : 212 SEWER FUND

DEPARTMENT: 345 ACCOUNTING & COLLECTION

INVOICE DATE RANGE: 1/01/1998 THRU 99/99/9999

PAY DATE RANGE: 12/08/2021 THRU 12/21/2021

BUDGET TO USE: CB-CURRENT BUDGET

VENDOR	NAME	ITEM #	G/L ACCOUNT	NAME	DESCRIPTION	CHECK #	AMOUNT
01-000090	MIDWEST MAILING &	I-P107801	212 5345-815	POSTAGE METER:	MAINTENANCE AGREEMEN	150837	409.00
01-000090	MIDWEST MAILING &	I-SI81226	212 5345-815	POSTAGE METER:	INK CARTRIDGE	150837	83.15
					VENDOR 01-000090 TOTALS		492.15
01-000720	CARDMEMBER SERVICES	I-202112160828	212 5345-516	TECHNOLOGY SU:	TAX & ACCOUNTING PRO	150768	141.67
					VENDOR 01-000720 TOTALS		141.67
01-001657	TYLER TECHNOLOGIES	I-025-360211	212 5345-516	TECHNOLOGY SU:	BEACON METER READING	150870	97.50
					VENDOR 01-001657 TOTALS		97.50
01-001663	ADVANCED DIGITAL SOLUT	I-IN35868	212 5345-814	PRINTING/COPY:	XEROX B8045	150751	10.28
01-001663	ADVANCED DIGITAL SOLUT	I-IN35983	212 5345-814	PRINTING/COPY:	XEROX 3330	150751	11.82
					VENDOR 01-001663 TOTALS		22.10
01-002655	MULTI-PRINT SOLUTIONS	I-3159	212 5345-311	OFFICE SUPPLI:	ENVELOPES	150840	330.50
					VENDOR 01-002655 TOTALS		330.50
01-003328	DOEHRING, WINDERS & CO	I-202112150812	212 5345-513	AUDITING SERV:	AUDITING SERVICES	150791	18,000.00
					VENDOR 01-003328 TOTALS		18,000.00
01-003490	INFOSEND, INC.	I-202946	212 5345-531	POSTAGE	: WATER/SEWER BILL PRI	150818	1,083.08
01-003490	INFOSEND, INC.	I-202946	212 5345-519	OTHER PROFESS:	WATER/SEWER BILL PRI	150818	295.94
					VENDOR 01-003490 TOTALS		1,379.02
01-003527	INB	I-202112160822	212 5345-811	BANK SERVICE :	EPAY FEES 11/2021	150815	7.44
					VENDOR 01-003527 TOTALS		7.44
01-003762	XEROX FINANCIAL SERVIC	I-2940402	212 5345-814	PRINTING/COPY:	LEASE PAYMENT	150879	64.75
					VENDOR 01-003762 TOTALS		64.75

VENDOR SET: 01 CITY OF MATTOON

BANK: APBNK

FUND : 212 SEWER FUND

DEPARTMENT: 345 ACCOUNTING & COLLECTION

INVOICE DATE RANGE: 1/01/1998 THRU 99/99/9999

PAY DATE RANGE: 12/08/2021 THRU 12/21/2021

BUDGET TO USE: CB-CURRENT BUDGET

VENDOR	NAME	ITEM #	G/L ACCOUNT	NAME	DESCRIPTION	CHECK #	AMOUNT
01-003880	NCR PAYMENT SOLUTIONS	I-202112150797	212 5345-811	BANK SERVICE :	EPAY FEES 11/2021	003979	1,332.32
					VENDOR 01-003880 TOTALS		1,332.32
01-004290	TYLER BUSINESS FORMS	I-65749	212 5345-311	OFFICE SUPPLI:	TAX FORMS	150869	39.74
					VENDOR 01-004290 TOTALS		39.74
01-017400	TSYS	I-202112150807	212 5345-811	BANK SERVICE :	FINANCE 12/2021 CC F	003982	160.39
					VENDOR 01-017400 TOTALS		160.39
01-023500	MOTION INDUSTRIES, INC	I-IL64-029157	212 5345-319	MISCELLANEOUS:	FLAGS	150839	288.44
					VENDOR 01-023500 TOTALS		288.44
01-023800	CONSOLIDATED COMMUNICA	I-202112100766	212 5345-532	TELEPHONE :	235-5483	003942	160.74
					VENDOR 01-023800 TOTALS		160.74
01-043522	STAPLES CREDIT PLAN	I-202112150817	212 5345-311	OFFICE SUPPLI:	OFFICE SUPPLIES	150862	44.17
					VENDOR 01-043522 TOTALS		44.17
DEPARTMENT 345 ACCOUNTING & COLLECTION TOTAL:							22,560.93
01-002602	DEAN BARBER	I-DEC2021-CELLDB	212 5346-533	CELLULAR PHON:	CELL PHONE	000283	33.34
					VENDOR 01-002602 TOTALS		33.34
01-003488	SSC SERVICES, INC.	I-8300	212 5346-460	OTHER PROPERT:	JANITORIAL SERVICES	150861	66.00
01-003488	SSC SERVICES, INC.	I-8304	212 5346-460	OTHER PROPERT:	JANITORIAL SERVICES	150861	66.00
					VENDOR 01-003488 TOTALS		132.00
01-003762	XEROX FINANCIAL SERVIC	I-2969997	212 5346-814	PRINT/COPY MA:	LEASE & USE	150880	70.21
					VENDOR 01-003762 TOTALS		70.21

VENDOR SET: 01 CITY OF MATTOON

BANK: APBNK

FUND : 212 SEWER FUND

DEPARTMENT: 346 ADMINISTRATIVE & GENERAL

INVOICE DATE RANGE: 1/01/1998 THRU 99/99/9999

PAY DATE RANGE: 12/08/2021 THRU 12/21/2021

BUDGET TO USE: CB-CURRENT BUDGET

VENDOR	NAME	ITEM #	G/L ACCOUNT	NAME	DESCRIPTION	CHECK #	AMOUNT
01-016000	JOHN DEERE FINANCIAL	I-202112160829	212 5346-319	MISCELLANEOUS:	JACKET,OVERALLS	150819	26.66
						VENDOR 01-016000 TOTALS	26.66

DEPARTMENT 346 ADMINISTRATIVE & GENERAL TOTAL: 262.21

VENDOR SET 212 SEWER FUND TOTAL: 105,836.86

REPORT GRAND TOTAL: 1,079,940.99

** G/L ACCOUNT TOTALS **

YEAR	ACCOUNT	NAME	AMOUNT	=====LINE ITEM=====		=====GROUP BUDGET=====	
				ANNUAL BUDGET	BUDGET OVER AVAILABLE BUDG	ANNUAL BUDGET	BUDGET OVER AVAILABLE BUDG
2021-2022	110-1141-002	DUE FROM REV. LOAN FUND	1,350.00				
	110-1141-007	DUE FROM LIBRARY	900.00				
	110-2172-000	DUE TO LIBRARY FUND	3,792.67				
	110-2172-001	DUE TO FIREFIGHTERS PENSIO	23,388.11				
	110-2172-002	DUE TO POLICE PENSION FUND	23,388.12				
	110-5110-532	TELEPHONE	59.77	600	126.93		
	110-5110-533	CELLULAR PHONE	200.00	3,000	1,400.00		
	110-5110-827	VGT ALLOCATION-DEMOLITIONS	9,010.00	48,000	5,493.80		
	110-5120-519	OTHER PROFESSIONAL SERVICE	306.00	16,550	1,668.06		
	110-5120-532	TELEPHONE	284.68	3,360	1,073.38		
	110-5120-814	PRINT/COPY MACH LEASE & MA	601.40	4,700	1,394.01		
	110-5130-565	CELLULAR PHONE EXP REIMB	100.00	1,200	400.00		
	110-5150-311	OFFICE SUPPLIES	39.74	500	255.73		
	110-5150-513	AUDITING & ACCOUNTING SERV	4,050.00	5,319	1,269.00		
	110-5150-516	TECHNOLOGY SUPPORT SERVIC	141.66	9,000	2,418.81		
	110-5150-532	TELEPHONE	159.79	2,000	723.20		
	110-5150-811	BANK SERVICE CHARGES	26.75	1,000	45.28		
	110-5150-814	PRINT/COPY MACH LEASE & MA	11.83	100	56.39-	Y	
	110-5160-515	LABOR RELATIONS COUNSEL	2,835.00	60,000	44,664.00		
	110-5160-519	OTHER PROFESSIONAL SERVICE	10.14	55,000	16,326.19		
	110-5170-325	SOFTWARE	256.00	2,400	2,144.00		
	110-5211-315	UNIFORMS & CLOTHING	558.10	5,000	3,779.89-	Y	
	110-5211-319	MISCELLANEOUS SUPPLIES	117.55	3,150	1,645.69		
	110-5211-519	OTHER PROFESSIONAL SERVICE	351.21	6,500	454.75		
	110-5211-532	TELEPHONE	1,750.00	16,400	1,556.87		
	110-5211-550	PRINTING & BINDING	178.90	2,000	1,584.68-	Y	
	110-5211-562	TRAVEL & TRAINING	170.00	22,500	1,623.32		
	110-5211-579	MISC OTHER PURCHASED SERVI	4,800.00	119,000	20,695.69		
	110-5211-814	PRINT/COPY MACH LEASE & MA	262.27	5,500	2,054.58		
	110-5211-825	SEIZURES/FORFEITURE EXP.	7,406.88	34,000	13,379.64		
	110-5212-319	MISCELLANEOUS SUPPLIES	504.43	9,000	4,454.54		
	110-5212-579	MISC OTHER PURCHASED SERVI	110.00	2,000	1,150.00		
	110-5213-579	MISC OTHER PURCHASED SERVI	500.00	21,000	3,877.00		
	110-5223-318	VEHICLE PARTS	15.00	4,000	1,688.41		
	110-5223-434	REPAIR OF VEHICLES	559.16	25,000	292.36-	Y	
	110-5224-316	TOOLS & EQUIPMENT	2.96	1,000	960.21		
	110-5224-321	UTILITIES	2,345.45	55,000	17,016.03		
	110-5224-439	OTHER REPAIR & MAINT SRVCS	1,109.83	15,000	10,791.12		
	110-5241-312	CLEANING SUPPLIES	155.78	4,200	1,124.70		
	110-5241-313	MEDICAL & SAFETY SUPPLIES	53.70	7,550	2,997.22		
	110-5241-315	UNIFORMS & CLOTHING	2,061.97	43,525	26,708.55		
	110-5241-316	TOOLS & EQUIPMENT	179.70	8,700	2,890.87		
	110-5241-319	MISCELLANEOUS SUPPLIES	78.28	3,400	2,306.54		
	110-5241-321	UTILITIES	204.30	8,200	3,145.71		
	110-5241-326	FUEL	37.07	12,000	1,963.05		
	110-5241-433	REPAIR OF MACHINERY	976.77	14,600	6,900.88		
	110-5241-434	REPAIR OF VEHICLES	2,726.23	23,000	27,513.70-	Y	

** G/L ACCOUNT TOTALS **

YEAR	ACCOUNT	NAME	AMOUNT	=====LINE ITEM=====		=====GROUP BUDGET=====	
				ANNUAL BUDGET	BUDGET OVER AVAILABLE BUDG	ANNUAL BUDGET	BUDGET OVER AVAILABLE BUDG
	110-5241-515	LABOR RELATIONS COUNSEL	8,310.00	40,000	3,420.08-		Y
	110-5241-519	OTHER PROFESSIONAL SERVICE	880.00	7,000	3,480.00		
	110-5241-532	TELEPHONE	471.96	8,500	3,183.02		
	110-5241-533	CELLULAR PHONE	100.00	1,200	400.00		
	110-5241-562	TRAVEL & TRAINING	1,000.00	48,850	31,649.71		
	110-5241-568	PHYSICALS	1,021.40	3,250	1,615.00-		Y
	110-5241-571	DUES & MEMBERSHIPS	450.00	1,700	197.50		
	110-5241-579	MISC OTHER PURCHASED SERVI	300.00	9,767	3,827.69		
	110-5241-814	PRINT/COPY MACH LEASE & MA	61.58	1,000	510.45		
	110-5261-311	OFFICE SUPPLIES	30.11	600	311.91		
	110-5261-434	REPAIR OF VEHICLES	1,463.21	500	4,245.62-		Y
	110-5261-533	CELLULAR PHONE	100.00	1,200	400.00		
	110-5310-319	MISCELLANEOUS SUPPLIES	26.66	500	41.73		
	110-5310-421	DISPOSAL SERVICES	2,092.83	28,000	10,281.21		
	110-5310-460	OTHER PROFESSIONAL SERVICE	132.00	3,500	1,170.04		
	110-5310-533	CELLULAR PHONE	33.33	1,200	548.83		
	110-5310-814	PRINT/COPY MACH LEASE & MA	72.35	1,000	373.79		
	110-5320-311	OFFICE SUPPLIES	155.74	100	151.61-		Y
	110-5320-313	MEDICAL & SAFETY SUPPLIES	125.96	2,500	1,769.77		
	110-5320-315	LANDSCAPING SUPPLIES	20.97	1,000	74.12-		Y
	110-5320-316	TOOLS & EQUIPMENT	148.62	10,000	7,534.27		
	110-5320-318	VEHICLE PARTS	122.93	17,000	10,271.20		
	110-5320-319	MISCELLANEOUS SUPPLIES	483.00	5,000	3,825.61		
	110-5320-321	UTILITIES	130.70	8,000	5,136.48		
	110-5320-326	FUEL	4.00	30,000	12,882.12		
	110-5320-432	REPAIR OF BUILDINGS	96.00	2,000	1,157.65		
	110-5320-433	REPAIR OF MACHINERY	1,759.27	25,000	15,555.79		
	110-5320-434	REPAIR OF VEHICLES	215.56	14,000	3,960.40		
	110-5320-440	RENTALS	3,415.63	6,000	858.03-		Y
	110-5320-460	OTHER PROP MAINT SERVICES	306.46	3,000	1,175.11-		Y
	110-5320-532	TELEPHONE	178.81	1,800	369.82		
	110-5320-533	CELLULAR PHONE	33.33	400	133.36		
	110-5320-814	PRINT/COPY MACH LEASE & MA	43.05	500	144.83		
	110-5381-319	MISCELLANEOUS SUPPLIES	672.42	2,000	39.55		
	110-5381-321	UTILITIES	1,100.90	50,000	19,333.27		
	110-5381-432	REPAIR OF BUILDINGS	5,297.75	16,000	4,337.07-		Y
	110-5381-460	OTHER PROP MAINT SERVICES	536.00	18,000	6,124.64		
	110-5511-316	TOOLS & EQUIPMENT	20.82	3,000	3,655.34-		Y
	110-5511-319	MISCELLANEOUS SUPPLIES	204.89	13,000	6,244.38-		Y
	110-5511-321	UTILITIES	708.84	23,000	9,223.68		
	110-5511-326	FUEL	495.75	9,000	1,564.64		
	110-5511-432	REPAIR OF BUILDINGS	2,462.66	0	2,462.66-		Y
	110-5511-433	REPAIR OF MACHINERY	1,194.42	10,000	833.44-		Y
	110-5511-440	RENTALS	80.00	3,500	2,320.00		
	110-5511-532	TELEPHONE	84.24	750	67.25		
	110-5511-825	TOURISM GRANT EXPENDITURES	2,671.24	25,000	13,280.85-		Y
	110-5512-317	CONCESSION & SOUVENIR SUPP	1,697.50	35,000	8,023.39		
	110-5512-319	MISCELLANEOUS SUPPLIES	62.23	18,000	1,906.62		

** G/L ACCOUNT TOTALS **

YEAR	ACCOUNT	NAME	AMOUNT	=====LINE ITEM=====		=====GROUP BUDGET=====	
				ANNUAL BUDGET	BUDGET OVER AVAILABLE BUDG	ANNUAL BUDGET	BUDGET OVER AVAILABLE BUDG
	110-5512-321	UTILITIES	1,088.42	36,000	2,758.75		
	110-5512-433	REPAIR OF MACHINERY	37.25	4,000	935.08		
	110-5512-440	RENTALS	80.00	4,000	1,420.00		
	110-5512-532	TELEPHONE	68.37	850	299.71		
	110-5512-576	SECURITY SERVICES	47.00	1,000	624.00		
	110-5551-321	UTILITIES	2,338.37	30,000	4,842.86		
	110-5551-440	RENTALS	160.00	5,000	2,830.28-	Y	
	110-5570-319	MISCELLANEOUS SUPPLIES	29.76	2,500	4,812.84-	Y	
	110-5570-321	UTILITIES	164.61	4,000	2,528.51		
	110-5570-326	FUEL	668.17	4,000	359.16-	Y	
	110-5570-433	REPAIR OF MACHINERY	410.48	5,000	3,877.84-	Y	
	110-5570-532	TELEPHONE	78.46	900	273.19		
	110-5651-571	DUES & MEMBERSHIPS	4,166.66	50,000	16,666.72		
	122-5653-311	OFFICE SUPPLIES	116.15	2,000	945.80		
	122-5653-321	NATURAL GAS & ELECTRIC (CI	114.26	2,600	528.07		
	122-5653-513	AUDITING SERVICES	1,350.00	1,773	423.00		
	122-5653-532	TELEPHONE	6.10	7,000	4,140.13		
	122-5653-533	CELLULAR PHONE	100.00	1,200	400.00		
	122-5653-540	ADVERTISING	347.00	20,000	14,883.32		
	122-5653-562	TRAVEL & TRAINING	140.00	5,000	3,579.85		
	122-5653-571	DUES & MEMBERSHIPS	1,000.00	500	1,000.00-	Y	
	122-5653-814	PRINTING/COPY MACH LEASE/M	51.35	1,500	659.72		
	123-5584-834	ENTERTAINMENT	379.22	45,000	1,893.88-	Y	
	123-5586-316	TOOLS & EQUIPMENT	168.09	1,000	245.53-	Y	
	123-5586-432	REPAIR OF STRUCTURES	329.37	20,000	14,087.41-	Y	
	123-5586-540	ADVERTISING	470.00	4,000	1,782.15-	Y	
	124-5342-742	SEWER COLLECTION VEHICLES	48,970.00	277,350	39,314.30		
	124-5344-742	WASTEWATER TRTMT PLANT VEH	52,780.00	44,574	8,206.00-	Y	
	124-5353-742	WATER TREATMENT PLANT VEHI	52,780.00	44,574	8,206.00-	Y	
	124-5354-742	WATER DIST VEHICLES	48,970.00	277,350	39,314.31		
	125-5150-250	WORKERS' COMPENSATION	203,062.50	532,766	146,884.61		
	125-5150-519	OTHER PROFESSIONAL SERVICE	78.00	90,000	78,883.00		
	125-5150-523	PROPERTY & CASUALTY INSURA	121,588.13	335,584	105,782.37		
	125-5150-527	SELF INSURED RETENTION/DED	7,219.80	50,000	11,618.49-	Y	
	128-5604-513	AUDITING SERVICES	1,350.00	1,700	350.00		
	128-5604-821	SHARED INCREMENT (20%)	126,082.65	152,000	15,306.20-	Y	
	128-5604-902	SIDEWALKS & CROSSWALKS	980.00	751,000	28,082.78		
	130-5321-730	IMPROVEMENTS OTHER THAN BL	44,575.80	635,669	181,969.22		
	150-5800-821	SHARED INCREMENT (20%)	4,815.22	6,600	227.51		
	151-5604-821	SHARED INCREMENT (20%)	10,244.73	13,000	636.89-	Y	
	153-5604-821	SHARED INCREMENT (20%)	27,937.77	33,040	3,933.01-	Y	
	154-5604-825	BUSINESS DISTRICT GRANTS	3,312.59	26,200	2,538.30		
	211-5351-321	NATURAL GAS & ELECTRIC	6.10	0	680.54-	Y	
	211-5353-312	CLEANING SUPPLIES	94.50	600	313.52		
	211-5353-319	MISCELLANEOUS SUPPLIES	5,578.69	21,000	5,303.52		
	211-5353-321	NATURAL GAS & ELECTRIC	2,004.70	140,000	68,913.59		
	211-5353-377	PLANT EQUIPMENT	2,297.49	20,000	17,408.08		
	211-5353-433	REPAIR OF MACHINERY	2,040.48	25,000	15,667.27		

** G/L ACCOUNT TOTALS **

YEAR	ACCOUNT	NAME	AMOUNT	=====LINE ITEM=====		=====GROUP BUDGET=====	
				ANNUAL BUDGET	BUDGET OVER AVAILABLE BUDG	ANNUAL BUDGET	BUDGET OVER AVAILABLE BUDG
	211-5353-434	REPAIR OF VEHICLES	85.85	1,500	61.52		
	211-5353-439	OTHER REPAIR & MAINT. SERV	104.13	3,000	853.04		
	211-5353-519	OTHER PROFESSIONAL SERVICE	640.00	15,000	11,525.00		
	211-5353-532	TELEPHONE	178.20	2,000	563.26		
	211-5353-533	CELLULAR PHONE	50.00	1,500	847.93		
	211-5354-311	OFFICE SUPPLIES	155.75	100	151.62-	Y	
	211-5354-313	MEDICAL & SAFETY SUPPLIES	125.97	2,000	1,250.98		
	211-5354-316	TOOLS & EQUIPMENT	337.54	17,000	6,912.28		
	211-5354-318	VEHICLE PARTS	122.94	7,500	789.78		
	211-5354-321	NATURAL GAS & ELECTRIC	565.45	29,000	15,109.09		
	211-5354-326	FUEL	4.00	30,000	12,882.10		
	211-5354-375	LEAK REPAIR MATERIALS	2,201.30	25,000	1,510.77		
	211-5354-376	BACKFILL & SURFACE MATERIA	1,130.09	12,000	3,426.74-	Y	
	211-5354-432	REPAIR OF STRUCTURES	96.00	2,500	1,657.65		
	211-5354-433	REPAIR OF MACHINERY	1,759.28	15,000	5,555.70		
	211-5354-434	REPAIR OF VEHICLES	215.59	11,000	573.23		
	211-5354-440	RENTALS	3,415.63	5,000	10,353.04-	Y	
	211-5354-460	OTHER PROPERTY MAINT. SERV	306.47	4,000	523.19-	Y	
	211-5354-519	OTHER PROFESSIONAL SERVICE	4,811.36	4,000	913.11-	Y	
	211-5354-532	TELEPHONE	178.82	2,000	569.76		
	211-5354-533	CELL PHONES	33.34	1,000	355.21		
	211-5354-730	IMPROVEMENTS OTHER THAN BL	14,667.56	360,000	31,676.82		
	211-5354-814	PRINTING/COPY MACH LEASE/M	41.79	600	255.27		
	211-5355-311	OFFICE SUPPLIES	414.41	1,500	400.83		
	211-5355-319	MISCELLANEOUS SUPPLIES	288.44	500	744.23-	Y	
	211-5355-513	AUDITING SERVICES	18,000.00	23,640	5,640.00		
	211-5355-516	TECHNOLOGY SUPPORT SERVICE	239.17	27,000	595.84		
	211-5355-519	OTHER PROFESSIONAL SERVICE	295.94	5,000	2,281.06		
	211-5355-531	POSTAGE	1,083.08	16,000	6,026.90		
	211-5355-532	TELEPHONE	160.73	3,000	1,115.12		
	211-5355-579	COLLECTION FEES	173.40	1,500	439.23-	Y	
	211-5355-811	BANK SERVICE CHARGES	1,500.14	15,000	2,541.69		
	211-5355-814	PRINTING/COPY MACH LEASE/M	86.85	1,500	805.20		
	211-5355-815	POSTAGE METER LEASE & MAIN	492.15	1,500	540.07		
	211-5356-319	MISCELLANEOUS SUPPLIES	26.66	500	97.63		
	211-5356-460	OTHER PROPERTY MAINT SVCS	132.00	3,500	1,170.03		
	211-5356-533	CELLULAR PHONE	33.33	1,200	548.77		
	211-5356-814	PRINT/COPY MACH LEASE & MA	70.21	1,000	392.22		
	212-5342-311	OFFICE SUPPLIES	155.78	100	151.65-	Y	
	212-5342-313	MEDICAL & SAFETY SUPPLIES	126.00	2,500	1,750.90		
	212-5342-316	TOOLS & EQUIPMENT	337.55	10,000	1,467.44-	Y	
	212-5342-318	VEHICLE PARTS	14,304.60	17,000	20,172.83-	Y	
	212-5342-321	UTILITIES	97.48	5,000	2,702.04		
	212-5342-326	FUEL	4.00	30,000	12,882.08		
	212-5342-363	BACKFILL & SURFACE MATERIA	3,438.44	20,000	8,173.16-	Y	
	212-5342-432	REPAIR OF STRUCTURES	96.00	15,000	15,612.38-	Y	
	212-5342-433	REPAIR OF MACHINERY	1,759.28	15,000	5,555.56		
	212-5342-434	REPAIR OF VEHICLES	215.60	15,000	4,959.95		

** G/L ACCOUNT TOTALS **

YEAR	ACCOUNT	NAME	AMOUNT	=====LINE ITEM=====		=====GROUP BUDGET=====	
				ANNUAL BUDGET	BUDGET OVER AVAILABLE BUDG	ANNUAL BUDGET	BUDGET OVER AVAILABLE BUDG
	212-5342-439	OTHER REPAIR & MTCE SERVIC	13,579.49	20,000	14.24		
	212-5342-440	RENTALS	3,665.64	10,000	991.91		
	212-5342-460	OTHER PROPERTY MTCE SERVIC	306.49	3,000	1,175.31-	Y	
	212-5342-532	TELEPHONE	178.81	2,000	569.77		
	212-5342-533	CELL PHONES	33.33	1,000	355.22		
	212-5342-814	PRINTING/COPY MACH LEASE/M	41.79	500	155.27		
	212-5343-321	NATURAL GAS & ELECTRIC	1,302.58	51,000	17,796.21		
	212-5344-311	OFFICE SUPPLIES	30.81	1,000	879.75		
	212-5344-316	TOOLS & EQUIPMENT	400.00	2,000	272.57		
	212-5344-319	MISCELLANEOUS SUPPLIES	451.15	6,000	1,244.87-	Y	
	212-5344-321	NATURAL GAS & ELECTRIC	10,149.82	240,000	96,413.08		
	212-5344-366	PLANT MTCE & REPAIR MATERI	308.47	30,000	26,662.07-	Y	
	212-5344-439	OTHER REPAIR & MNTCE SERVI	90.75	14,000	6,234.56		
	212-5344-460	OTHER PROPERTY MTCE SERVIC	249.02	30,000	21,194.21		
	212-5344-516	TECHNOLOGY SUPPORT SERVICE	64.00	4,000	3,036.00		
	212-5344-562	TRAVEL & TRAINING	141.00	800	422.00		
	212-5344-730	IMPROVEMENTS OTHER THAN BL	31,442.65	470,000	255,105.56-	Y	
	212-5344-814	COPY MACHINE	43.19	800	401.28		
	212-5345-311	OFFICE SUPPLIES	414.41	1,500	400.84		
	212-5345-319	MISCELLANEOUS SUPPLIES	288.44	500	744.24-	Y	
	212-5345-513	AUDITING SERVICES	18,000.00	23,640	5,640.00		
	212-5345-516	TECHNOLOGY SUPPORT SERVICE	239.17	31,000	2,595.84		
	212-5345-519	OTHER PROFESSIONAL SERVICE	295.94	5,000	2,281.08		
	212-5345-531	POSTAGE	1,083.08	16,000	6,026.88		
	212-5345-532	TELEPHONE	160.74	3,000	1,115.12		
	212-5345-811	BANK SERVICE CHARGES	1,500.15	15,000	2,542.63		
	212-5345-814	PRINTING/COPY MACH LEASE/M	86.85	1,500	805.22		
	212-5345-815	POSTAGE METER LEASE & MTCE	492.15	1,500	540.08		
	212-5346-319	MISCELLANEOUS SUPPLIES	26.66	500	97.62		
	212-5346-460	OTHER PROPERTY MAINT SVCS	132.00	3,500	1,170.03		
	212-5346-533	CELLULAR PHONE	33.34	1,200	548.69		
	212-5346-814	PRINT/COPY MACH LEASE & MA	70.21	1,000	392.22		
		TOTAL:	1,079,940.99				

** DEPARTMENT TOTALS **

ACCT	NAME	AMOUNT
110	NON-DEPARTMENTAL	52,818.90
110-110	CITY COUNCIL	9,269.77
110-120	CITY CLERK	1,192.08
110-130	CITY ADMINISTRATOR	100.00
110-150	FINANCIAL ADMINISTRATION	4,429.77
110-160	LEGAL SERVICES	2,845.14

** DEPARTMENT TOTALS **

ACCT	NAME	AMOUNT
110-170	COMPUTER INFO SYSTEMS	256.00
110-211	POLICE ADMINISTRATION	15,594.91
110-212	CRIMINAL INVESTIGATION	614.43
110-213	PATROL	500.00
110-223	AUTOMOTIVE SERVICES	574.16
110-224	POLICE BUILDINGS	3,458.24
110-241	FIRE PROTECTION ADMIN.	19,068.74
110-261	COMMUNITY DEVELOPMENT	1,593.32
110-310	PUBLIC WORKS	2,357.17
110-320	STREETS	7,240.03
110-381	CUSTODIAL SERVICES	7,607.07
110-511	PARKS	7,922.86
110-512	LAKE MATTOON	3,080.77
110-551	SPORTS FACILITIES	2,498.37
110-570	DODGE GROVE CEMETERY	1,351.48
110-651	ECONOMIC DEVELOPMENT	4,166.66

110 TOTAL	GENERAL FUND	148,539.87
122-653	HOTEL TAX ADMINISTRATION	3,224.86

122 TOTAL	HOTEL TAX FUND	3,224.86
123-584	BAGELFEST	379.22
123-586	LIGHTWORKS	967.46

123 TOTAL	FESTIVAL MGMT FUND	1,346.68
124-342	SEWER COLL VEH & MACH	48,970.00
124-344	WASTEWATER TRTMT VEH & MA	52,780.00
124-353	WATER TRTMT VEH & MACH	52,780.00
124-354	WATER VEHICLES & MACHINE	48,970.00

124 TOTAL	MOBILE EQUIPMENT FUND	203,500.00
125-150	FINANCIAL ADMINISTRATION	331,948.43

125 TOTAL	INSURANCE & TORT JDGMNT	331,948.43
128-604	MIDTOWN TIF DISTRICT	128,412.65

128 TOTAL	MIDTOWN TIF FUND	128,412.65
130-321	STREETS	44,575.80

130 TOTAL	CAPITAL PROJECT FUND	44,575.80
150-800	SHARED INCREMENT	4,815.22

150 TOTAL	I-57 EAST TIF DISTRICT	4,815.22
151-604	SOUTH RT 45 TIF DISTRICT	10,244.73

** DEPARTMENT TOTALS **

ACCT	NAME	AMOUNT
151 TOTAL	SOUTH RT 45 TIF DISTRICT	10,244.73
153-604	BROADWAY EAST TIF DIST	27,937.77
153 TOTAL	BROADWAY EAST TIF DIST	27,937.77
154-604	BROADWAY EAST BUSINESS DI	3,312.59
154 TOTAL	BROADWAY EAST BUS DIST	3,312.59
211-351	RESERVOIRS & WTR SOURCES	6.10
211-353	WATER TREATMENT PLANT	13,074.04
211-354	WATER DISTRIBUTION	30,168.88
211-355	ACCOUNTING & COLLECTION	22,734.31
211-356	ADMINISTRATIVE & GENERAL	262.20
211 TOTAL	WATER FUND	66,245.53
212-342	SEWER COLLECTION SYSTEM	38,340.28
212-343	SEWER LIFT STATIONS	1,302.58
212-344	WASTEWATER TREATMNT PLANT	43,370.86
212-345	ACCOUNTING & COLLECTION	22,560.93
212-346	ADMINISTRATIVE & GENERAL	262.21
212 TOTAL	SEWER FUND	105,836.86
	** TOTAL **	1,079,940.99

NO ERRORS

VENDOR SET: 01 CITY OF MATTOON

BANK: EHBK

FUND : 221 HEALTH INSURANCE FUND

DEPARTMENT: 411 STOP LOSS INS COVERAGE

INVOICE DATE RANGE: 1/01/1998 THRU 99/99/9999

PAY DATE RANGE: 12/08/2021 THRU 12/21/2021

BUDGET TO USE: CB-CURRENT BUDGET

VENDOR	NAME	ITEM #	G/L ACCOUNT	NAME	DESCRIPTION	CHECK #	AMOUNT
01-003657	AETNA	I-H9575482	221 5411-211	STOP LOSS INS:	DECEMBER STOP LOSS	150719	57,747.96
						VENDOR 01-003657 TOTALS	57,747.96
						DEPARTMENT 411 STOP LOSS INS COVERAGE TOTAL:	57,747.96
01-003493	WAGeworks, INC.	I-1021-TR39409	221 5412-211	HEALTH PLAN A:	OCTOBER COBRA	150885	43.90
01-003493	WAGeworks, INC.	I-1121-TR39409	221 5412-211	HEALTH PLAN A:	NOVEMBER COBRA	150885	74.03
						VENDOR 01-003493 TOTALS	117.93
01-003657	AETNA	I-H9575481	221 5412-211	HEALTH PLAN A:	DECEMBER SUPPLEMENT	150719	23,520.32
01-003657	AETNA	I-H9575482	221 5412-211	HEALTH PLAN A:	DECEMBER ADMIN	150719	72.50
						VENDOR 01-003657 TOTALS	23,592.82
						DEPARTMENT 412 HEALTH PLAN ADMIN TOTAL:	23,710.75
01-003639	AETNA	I-202112100739	221 5413-211	MEDICAL CLAIM:	AETNA	003973	20,047.26
01-003639	AETNA	I-202112160858	221 5413-211	MEDICAL CLAIM:	AETNA	003986	61,052.47
						VENDOR 01-003639 TOTALS	81,099.73
						DEPARTMENT 413 MEDICAL CLAIMS TOTAL:	81,099.73
01-003639	AETNA	I-202112100739	221 5414-211	RX CLAIMS	: AETNA	003973	25,333.55
01-003639	AETNA	I-202112160858	221 5414-211	RX CLAIMS	: AETNA	003986	16,220.19
						VENDOR 01-003639 TOTALS	41,553.74
						DEPARTMENT 414 RX CLAIMS TOTAL:	41,553.74
01-004292	JACQUELYN COOK	I-202112100738	221 5416-211	REFUNDS REIMB:	REIMBURSE QHDHP	150720	50.00
						VENDOR 01-004292 TOTALS	50.00
						DEPARTMENT 416 REFUNDS REIMB & MISC EXPSTOTAL:	50.00

VENDOR SET: 01 CITY OF MATTOON

BANK: EHBK

FUND : 221 HEALTH INSURANCE FUND

DEPARTMENT: 417 LIFE INSURANCE

INVOICE DATE RANGE: 1/01/1998 THRU 99/99/9999

PAY DATE RANGE: 12/08/2021 THRU 12/21/2021

BUDGET TO USE: CB-CURRENT BUDGET

VENDOR	NAME	ITEM #	G/L ACCOUNT	NAME	DESCRIPTION	CHECK #	AMOUNT
01-001982	DEARBORN LIFE INSURANC	I-202112150811	221 5417-212	LIFE INSURANC:	JANUARY LIFE INSURAN	150883	2,254.23
						VENDOR 01-001982 TOTALS	2,254.23
						DEPARTMENT 417 LIFE INSURANCE	TOTAL: 2,254.23
01-002761	OPTUM	I-10199064884	221 5418-212	SECTION 125 B:	NOVEMBER FSA	150884	150.00
						VENDOR 01-002761 TOTALS	150.00
						DEPARTMENT 418 SECTION 125 PLAN	TOTAL: 150.00
						VENDOR SET 221 HEALTH INSURANCE FUND	TOTAL: 206,566.41
						REPORT GRAND TOTAL:	206,566.41

** G/L ACCOUNT TOTALS **

YEAR	ACCOUNT	NAME	AMOUNT	=====LINE ITEM=====		=====GROUP BUDGET=====	
				ANNUAL BUDGET	BUDGET OVER AVAILABLE BUDG	ANNUAL BUDGET	BUDGET OVER AVAILABLE BUDG
2021-2022	221-5411-211	STOP LOSS INSURANCE	57,747.96	700,348		251,265.46	
	221-5412-211	HEALTH PLAN ADMINISTRATION	23,710.75	609,660		207,648.05	
	221-5413-211	MEDICAL CLAIMS	81,099.73	2,993,426		1,502,217.78	
	221-5414-211	RX CLAIMS	41,553.74	1,178,744		563,526.73	
	221-5416-211	REFUNDS REIMBURSEMENTS & M	50.00	0		3,247.97-	Y
	221-5417-212	LIFE INSURANCE	2,254.23	28,424		10,525.82	
	221-5418-212	SECTION 125 BENEFIT PLAN A	150.00	1,800		600.00	
		TOTAL:	206,566.41				

** DEPARTMENT TOTALS **

ACCT	NAME	AMOUNT
221-411	STOP LOSS INS COVERAGE	57,747.96
221-412	HEALTH PLAN ADMIN	23,710.75
221-413	MEDICAL CLAIMS	81,099.73
221-414	RX CLAIMS	41,553.74
221-416	REFUNDS REIMB & MISC EXPS	50.00
221-417	LIFE INSURANCE	2,254.23
221-418	SECTION 125 PLAN	150.00
221 TOTAL	HEALTH INSURANCE FUND	206,566.41
	** TOTAL **	206,566.41

NO ERRORS

VENDOR SET: 01 CITY OF MATTOON

BANK: DDBNK

FUND : 221 HEALTH INSURANCE FUND

DEPARTMENT: 415 DENTAL CLAIMS

INVOICE DATE RANGE: 1/01/1998 THRU 99/99/9999

PAY DATE RANGE: 12/08/2021 THRU 12/21/2021

BUDGET TO USE: CB-CURRENT BUDGET

VENDOR	NAME	ITEM #	G/L ACCOUNT	NAME	DESCRIPTION	CHECK #	AMOUNT
01-000276	DELTA DENTAL-ASC	I-202112100768	221 5415-211	DENTAL CLAIMS: DELTA DENTAL-ASC		003972	2,905.43
01-000276	DELTA DENTAL-ASC	I-202112150799	221 5415-211	DENTAL CLAIMS: DELTA DENTAL-ASC		003985	1,083.30
						VENDOR 01-000276 TOTALS	3,988.73

DEPARTMENT 415 DENTAL CLAIMS TOTAL: 3,988.73

VENDOR SET 221 HEALTH INSURANCE FUND TOTAL: 3,988.73

REPORT GRAND TOTAL: 3,988.73

** G/L ACCOUNT TOTALS **

YEAR	ACCOUNT	NAME	AMOUNT	=====LINE ITEM=====		=====GROUP BUDGET=====	
				ANNUAL BUDGET	BUDGET OVER AVAILABLE BUDG	ANNUAL BUDGET	BUDGET OVER AVAILABLE BUDG
2021-2022	221-5415-211	DENTAL CLAIMS	3,988.73	97,064	47,904.94		
		TOTAL:	3,988.73				

** DEPARTMENT TOTALS **

ACCT	NAME	AMOUNT
221-415	DENTAL CLAIMS	3,988.73

221 TOTAL	HEALTH INSURANCE FUND	3,988.73

	** TOTAL **	3,988.73

NO ERRORS

VENDOR SET: 01 CITY OF MATTOON

BANK: MFTBK

FUND : 121 MOTOR FUEL TAX FUND

DEPARTMENT: 321 STREETS

INVOICE DATE RANGE: 1/01/1998 THRU 99/99/9999

PAY DATE RANGE: 12/08/2021 THRU 12/21/2021

BUDGET TO USE: CB-CURRENT BUDGET

VENDOR	NAME	ITEM #	G/L ACCOUNT	NAME	DESCRIPTION	CHECK #	AMOUNT
01-001001	NE-CO ASPHALT CO., INC	I-57049	121 5321-354	HOT MIX ASPHA:	ASPHALT	150887	5,760.00
						VENDOR 01-001001 TOTALS	5,760.00
01-045400	UPCHURCH GROUP INC	I-202112150814	121 5321-730	IMPROVEMENTS :	DEWITT AVE RESURFACI	150889	5,696.26
						VENDOR 01-045400 TOTALS	5,696.26
DEPARTMENT 321 STREETS						TOTAL:	11,456.26
01-002194	IL POWER MARKETING DBA I-1461321111*		121 5326-321	NATURAL GAS &:	9TH & CHARLESTON	150886	8.52
01-002194	IL POWER MARKETING DBA I-1461321111*		121 5326-321	NATURAL GAS &:	19TH & RICHMOND	150886	7.19
01-002194	IL POWER MARKETING DBA I-1461321111*		121 5326-321	NATURAL GAS &:	208 N 19TH STREET	150886	2,159.78
01-002194	IL POWER MARKETING DBA I-1461321111*		121 5326-321	NATURAL GAS &:	7TH & CHARLESTON	150886	7.05
01-002194	IL POWER MARKETING DBA I-1461321111*		121 5326-321	NATURAL GAS &:	14TH & CHARLESTON	150886	6.58
01-002194	IL POWER MARKETING DBA I-1461321111*		121 5326-321	NATURAL GAS &:	208 N 19TH ST	150886	1,039.38
01-002194	IL POWER MARKETING DBA I-1461321111*		121 5326-321	NATURAL GAS &:	LOGAN & CHARLESTON	150886	5.96
01-002194	IL POWER MARKETING DBA I-1461321111*		121 5326-321	NATURAL GAS &:	15TH & CHARLESTON	150886	6.77
01-002194	IL POWER MARKETING DBA I-1461321111*		121 5326-321	NATURAL GAS &:	18TH & MARSHALL	150886	10.17
01-002194	IL POWER MARKETING DBA I-1461321111*		121 5326-321	NATURAL GAS &:	18TH & CHARLESTON	150886	6.20
01-002194	IL POWER MARKETING DBA I-1461321111*		121 5326-321	NATURAL GAS &:	19TH & WESTERN	150886	65.40
01-002194	IL POWER MARKETING DBA I-1461321111*		121 5326-321	NATURAL GAS &:	6TH & CHARLESTON	150886	7.62
01-002194	IL POWER MARKETING DBA I-1461321111*		121 5326-321	NATURAL GAS &:	CHARLESTON & SWORDS	150886	8.56
01-002194	IL POWER MARKETING DBA I-1461321111*		121 5326-321	NATURAL GAS &:	B'DWAY & CHARLESTON	150886	169.45
01-002194	IL POWER MARKETING DBA I-1461321111*		121 5326-321	NATURAL GAS &:	19TH & CHARLESTON	150886	5.96
01-002194	IL POWER MARKETING DBA I-1461321111*		121 5326-321	NATURAL GAS &:	CHARLESTON & CRESTVI	150886	9.04
						VENDOR 01-002194 TOTALS	3,523.63
01-023800	CONSOLIDATED COMMUNICA I-202112100761		121 5326-321	NATURAL GAS &:	235-5663	003974	52.60
						VENDOR 01-023800 TOTALS	52.60
DEPARTMENT 326 STREET LIGHTING						TOTAL:	3,576.23
01-002776	PALS ELECTRIC INC.	I-12447	121 5327-432	REPAIR OF STR:	14TH & B'DWAY RETROF	150888	3,420.00
01-002776	PALS ELECTRIC INC.	I-12448	121 5327-432	REPAIR OF STR:	15TH & B'DWAY RETROF	150888	2,565.00
01-002776	PALS ELECTRIC INC.	I-12449	121 5327-432	REPAIR OF STR:	16TH & B'DWAY RETROF	150888	3,420.00
01-002776	PALS ELECTRIC INC.	I-12526	121 5327-432	REPAIR OF STR:	19TH & BROADWAY LIGH	150888	255.00
01-002776	PALS ELECTRIC INC.	I-12530	121 5327-432	REPAIR OF STR:	LAKELAND & MARSHALL	150888	3,589.34

VENDOR SET: 01 CITY OF MATTOON

BANK: MFTBK

FUND : 121 MOTOR FUEL TAX FUND

DEPARTMENT: 327 TRAFFIC CONTROL DEVICES

INVOICE DATE RANGE: 1/01/1998 THRU 99/99/9999

PAY DATE RANGE: 12/08/2021 THRU 12/21/2021

BUDGET TO USE: CB-CURRENT BUDGET

VENDOR	NAME	ITEM #	G/L ACCOUNT	NAME	DESCRIPTION	CHECK #	AMOUNT
01-002776	PALS ELECTRIC INC.	I-12531	121 5327-432	REPAIR OF STR:	19TH & BROADWAY REPA	150888	132.37
						VENDOR 01-002776 TOTALS	13,381.71

DEPARTMENT 327 TRAFFIC CONTROL DEVICES TOTAL: 13,381.71

VENDOR SET 121 MOTOR FUEL TAX FUND TOTAL: 28,414.20

REPORT GRAND TOTAL: 28,414.20

** G/L ACCOUNT TOTALS **

YEAR	ACCOUNT	NAME	AMOUNT	=====LINE ITEM=====		=====GROUP BUDGET=====	
				ANNUAL BUDGET	BUDGET OVER AVAILABLE BUDG	ANNUAL BUDGET	BUDGET OVER AVAILABLE BUDG
2021-2022	121-5321-354	HOT MIX ASPHALT	5,760.00	100,000	9,280.00-	Y	
	121-5321-730	IMPROVEMENTS OTHER THAN BL	5,696.26	910,816	452,569.04		
	121-5326-321	NATURAL GAS & ELECTRIC	3,576.23	150,000	65,536.73		
	121-5327-432	REPAIR OF STRUCTURE	13,381.71	24,000	4,020.92-	Y	
		TOTAL:	28,414.20				

** DEPARTMENT TOTALS **

ACCT	NAME	AMOUNT
121-321	STREETS	11,456.26
121-326	STREET LIGHTING	3,576.23
121-327	TRAFFIC CONTROL DEVICES	13,381.71

121 TOTAL	MOTOR FUEL TAX FUND	28,414.20

	** TOTAL **	28,414.20

NO ERRORS

ACCOUNT	NAME	DATE	TYPE	CK #	AMOUNT	DEPOSIT			MESSAGE
						CODE	RECEIPT	AMOUNT	
01-00900-03	SWEET, SCOTT & CHERYL	12/10/21	FINAL BILL	150721	52.84CR	100	ONLINE	60.00CR	
01-24200-01	BROWN, MARK	12/10/21	FINAL BILL	150722	53.50CR	100	ONLINE	60.00CR	
02-03700-01	WILLIAMS, DAN	12/10/21	FINAL BILL	150723	28.50CR	000		0.00	
03-03500-05	ARCH REGENCY PROPERTIES LL	12/10/21	FINAL BILL	150724	36.65CR	100	ONLINE	60.00CR	
03-18700-07	MCCOY, JOHNNIE	12/10/21	FINAL BILL	150725	118.64CR	000		0.00	
03-23400-03	DAVEE, AMY J	12/10/21	FINAL BILL	150726	51.27CR	100	ONLINE	60.00CR	
04-22810-11	DODSON, NATHAN R	12/10/21	FINAL BILL	150727	14.36CR	100	46433	60.00CR	
07-03400-04	HARTBANK, SHANNON D	12/10/21	FINAL BILL	150728	64.62CR	100	45825	60.00CR	
07-18600-14	RHODES, BRYAN D	12/10/21	FINAL BILL	150729	51.58CR	100	46889	60.00CR	
07-20410-20	PAYNE, CHASITY D	12/10/21	FINAL BILL	150730	53.18CR	100	46282	60.00CR	

ACCOUNT	NAME	DATE	TYPE	CK #	AMOUNT	CODE	RECEIPT	AMOUNT	MESSAGE
10-10000-04	ARD, JIMMIE L	12/17/21	FINAL BILL	150747	17.02CR	000		0.00	

NEW BUSINESS:

City of Mattoon Council Decision Request

MEETING DATE: 12-21-2021 CDR NO: 2021-2201

SUBJECT: Promotion of Sergeant Michael A. Johnson to the rank of Lieutenant effective December 25, 2021

SUBMITTAL DATE: 12-06-2021

SUBMITTED BY: Sam Gaines, Chief of Police, Mattoon Police Dept.

APPROVED FOR
COUNCIL AGENDA: Kyle Gill, City Administrator 12/16/2021
Date

EXHIBITS (If applicable):

EXPENDITURE	AMOUNT	FUNDS	CONTINGENCY
ESTIMATE:	BUDGETED:	REMAINING:	FUNDING:
\$76,210.63	\$2,194,787.00	\$665,690.40	\$0.00

IF IT IS THE WISH OF THE COUNCIL TO SUPPORT RECOMMENDATIONS CONTAINED IN THIS REPORT, THE FOLLOWING MOTION IS SUGGESTED:

“I move that the City Council promote Sergeant Michael Johnson to the rank of Lieutenant in the Mattoon Police Department effective December 25, 2021”

SUMMARY OF THE TOPIC FOR WHICH A COUNCIL DECISION IS REQUESTED:

An opening in the rank of Lieutenant occurred with Lieutenant Donald Sweeney retiring effective October 22, 2021. In accordance with the PBPA Contract, promotions should take effect within 60 days of the position becoming available. In order to maintain the appropriate supervisory staff level at Mattoon Police Department, the vacant rank should be filled at this time. We ask for Sgt. Michael Johnson to be promoted to Lieutenant to fill the current vacancy.

**City of Mattoon
Council Decision Request**

MEETING DATE: 12-21-2021 CDR NO: 2021-2202

SUBJECT: Status change for Officer Robert Agney

SUBMITTAL DATE: 12-08-2021

SUBMITTED BY: Sam Gaines, Chief of Police, Mattoon Police Dept.

APPROVED FOR Kyle Gill, 12/16/2021
COUNCIL AGENDA: City Administrator Date

EXHIBITS (If applicable): None

EXPENDITURE	AMOUNT	FUNDS	CONTINGENCY
ESTIMATE:	BUDGETED:	REMAINING:	FUNDING:
\$62,722.09	\$2,194,787.00	\$665,690.40	\$0.00

IF IT IS THE WISH OF THE COUNCIL TO SUPPORT RECOMMENDATIONS
CONTAINED IN THIS REPORT, THE FOLLOWING MOTION IS SUGGESTED:

“I move that the City Council appoint and designate Officer Robert Agney as a regular full-time Police Officer with the Mattoon Police Department effective 1/2/2022. He has successfully completed one full year as a Probationary Police Officer as of that date.

SUMMARY OF THE TOPIC FOR WHICH A COUNCIL DECISION IS REQUESTED:

The City of Mattoon hired Officer Robert Agney on January 2, 2021, as a Probationary Police Officer with the Mattoon Police Department. Officer Agney’s written training evaluation portfolio indicates successful completion of one full year of service on January 2, 2022. Therefore, it is the recommendation of Chief Sam Gaines that Officer Agney should be appointed as regular full-time Police Officer effective on January 2, 2022, and per the Police Officers’ contract with the City of Mattoon, his salary should be adjusted accordingly.

Memo

To: City Administrator, Mayor & Commissioners
From: Dean Barber
Date: December 07, 2021
Re: Dewitt Avenue Patching - 2020

We completed a patching project in 2020 at the intersection of 12th & Dewitt and the intersection of Logan & Dewitt.

The final project cost was \$16,496.59.

We authorized \$15,000.00 of MFT Funds in advance of the project.

The attached MFT Resolution is necessary to authorize the remaining \$1,496.59.





CITY OF MATTOON, ILLINOIS
RESOLUTION NO. 2021-3168
Resolution for Improvement Under the Illinois Highway Code



Is this project a bondable capital improvement?

Yes No

Resolution Type	Resolution Number	Section Number
Supplemental	2021- 3168	19-00314-00-PP

BE IT RESOLVED, by the Council of the City of Mattoon Illinois that the following described street(s)/road(s)/structure be improved under the Illinois Highway Code. Work shall be done by Contract.

Governing Body Type Local Public Agency Type

Name of Local Public Agency

Contract or Day Labor

For Roadway/Street Improvements:

Name of Street(s)/Road(s)	Length (miles)	Route	From	To
Dewitt Avenue	1		12th Street	Logan Street

For Structures:

Name of Street(s)/Road(s)	Existing Structure No.	Route	Location	Feature Crossed

BE IT FURTHER RESOLVED,

1. That the proposed improvement shall consist of

Pavement patching at the intersection of Dewitt Avenue & 12th Street and the intersection of Dewitt Ave & Logan Street.

2. That there is hereby appropriated the sum of One-thousand four hundred ninety six and 59/100 Dollars (\$1,496.59) for the improvement of said section from the Local Public Agency's allotment of Motor Fuel Tax funds.

BE IT FURTHER RESOLVED, that the Clerk is hereby directed to transmit four (4) certified originals of this resolution to the district office of the Department of Transportation.

I, _____ City Clerk in and for said City

Name of Clerk Local Public Agency Type Local Public Agency Type

of Mattoon in the State aforesaid, and keeper of the records and files thereof, as provided by statute, do hereby certify the foregoing to be a true, perfect and complete original of a resolution adopted by

Name of Local Public Agency

Council of Mattoon at a meeting held on 12/21/2021.

Governing Body Type Name of Local Public Agency Date

IN TESTIMONY WHEREOF, I have hereunto set my hand and seal this 21st day of December, 2021.

Day Month, Year

(SEAL)

Clerk Signature	Date
	12/21/2021

Approved

Regional Engineer Department of Transportation	Date

**City of Mattoon
Council Decision Request**

MEETING DATE: 12/21/2021 CDR NO: 2021-2203

SUBJECT: Bid Award – Depot Surveillance System

SUBMITTAL DATE: 12/15/2021

SUBMITTED BY: Dean Barber, Public Works Director

APPROVED FOR Kyle Gill, 12/16/2021
COUNCIL AGENDA: City Administrator Date

EXHIBITS (If applicable): Consolidated Communications Bid, Camera Schedule

EXPENDITURE	AMOUNT	CONTINGENCY FUNDING
ESTIMATE: \$47,882.50	BUDGETED: \$25,000.00	REQUIRED: \$22,882.50

IF IT IS THE WISH OF THE COUNCIL TO SUPPORT RECOMMENDATIONS CONTAINED IN THIS REPORT, THE FOLLOWING MOTION IS SUGGESTED:

“I move to accept the bid in the amount of \$47,882.50 from Consolidated Communications for the replacement of the Video Surveillance System at the Depot.”

SUMMARY OF THE TOPIC FOR WHICH A COUNCIL DECISION IS REQUESTED:

The bid opening was held on December 15, 2021. The following bids were received:

Consolidated Communications Enterprise Services (Champaign)	\$47,882.50
Detection Security (Mattoon)	\$56,545.20
Heart Technologies (Decatur)	\$62,295.20
Premier Fire & Safety (Effingham)	\$69,675.00

This project includes the complete replacement of the video surveillance system at the Depot. The existing system was installed with the building renovation in 2009. The cameras are not of sufficient quality, and/or adequately placed, to allow for prosecution of vandalism in the building. We are also adding coverage for Heritage Park and Progress Square Parking Lot.

The work includes the removal of 20 cameras and the installation of 18. It also includes a new server and software. The proposed system will be connected to the existing surveillance system at the Police Department at the end of the project.

The new cameras include motion activation so they only record when activity is occurring. This reduces data storage requirements and review time for officers. The cameras will also be “facial recognition quality” to improve identification and prosecution rates.

I apologize for the disparity between the budget amount and the low bid. I misunderstood the scope of work required to update the system when budgeting last year.

We recommend awarding the bid to Consolidated Communications. This project, and the resulting improvements to our ability to deter vandalism downtown, are long overdue.

This work is being paid from TIF Funds.

PROPOSAL FORM

I/We agree to provide the items described in the Request for Proposals titled "City of Mattoon Illinois, Depot Surveillance System, November 2021" at the following price(s):

ITEM	QTY	Price
Depot Surveillance System	LS	<u>\$47,882.50</u>

Attach a Bid Bond of not less than 5% of the bid price.

Vendor Name and Address

Consolidated Communications

Phone: 217-353-5422

1300 S Neil St

Fax: 217-398-5923

Champaign,IL

Email: zachary.harrell@consolidated.com

Signature  _____

CAMERA SCHEDULE

Camera Installation #	Location	Dome/Bullet	# of Cameras	Min. Coverage (Degrees)	Indoor/Outdoor	Infra-Red	Mounting Height	Wall/Ceiling Mount	Focal Point	Horizontal Distance	Facial Recognition Req'd	Camera Removal
F1	East Bus Stop (Covered)	Dome	1	90	Outdoor	Yes	*13'	Wall	Parking Lot	50'	Yes	2
F2	Tourism Office	Dome	1	45	Indoor	Yes	12'	Either	Adjacent Door	20'	Yes	1
F3	Tourism Office	Dome	1	45	Indoor	Yes	12'	Either	Adjacent Door	20'	Yes	1
F4	Lobby 102	Dome	1	90	Indoor	No	12'	Either	Lobby Area	12' to 25'	Yes	1
F5	Lobby 103	Dome	1	90	Indoor	No	14'	Either	Lobby/Elevator/Door	8' to 25'	Yes	2
F6	North Patio (Covered)	Dome	1	45	Outdoor	Yes	*9'-6"	Wall	Patio Gate/Garage	50' to 75'	Yes	1
F7	Stair 114	Dome	1	45	Indoor	No	20'	Dome Ceiling	Upstairs	22'	Yes	1
F8	Stair 114	Dome	1	45	Indoor	No	20'	Dome Ceiling	Downstairs	22'	Yes	0
F9	Grand Foyer	Dome	1	45	Indoor	No	18'	Dome Ceiling	Grand Foyer	25'	Yes	1
F10	South Porch (Covered)	Dome	1	45	Outdoor	Yes	*14'	Wall	Porch/Street	30'	Yes	1
M1	Stair M08	Dome	1	90	Indoor	No	9'	Wall	West/Downstairs	20'	Yes	1
B1	Waiting Area	Dome	1	90	Indoor	No	**18'	Ceiling	Waiting Area/Door	25'	Yes	3
B2	Waiting Area	Dome	1	90	Indoor	No	**18'	Ceiling	Waiting Area/Door	25'	Yes	2
B3	Waiting Area	Bullet	1	45	Indoor	No	***13'	Wall	Women's Room Door	105'	Yes	0
B4	Passenger Platform (Not Covered)	Dome	2	180	Outdoor	Yes	20'	Wall	Platform	12' to 25'	Yes	2
B5	Waiting Area	Dome	1	90	Indoor	No	**18'	Ceiling	Waiting Area	25'	Yes	1
HP1	South Side of Depot	Bullet	1	45	Outdoor	Yes	20'	Wall	Heritage Park	150' to 200'	Yes	0
PS1	Progress Square Parking Lot	Dome	1	90	Outdoor	Yes	16'	Wall	Parking Lot	60' to 85'	Yes	0

* Mount Lower than Roof/Ceiling Beams.

** Mount on Bottom of Ceiling Beam

*** Mount just above Ledge.

These distances are the horizontal distances for aiming the cameras. Please aim at a target 5'H. The focal distance range of each camera shall be a min of 25% less than and greater than the distances shown above.

COPYRIGHT © 2007 HANCE, UTZ & ASSOCIATES, P.C. RESERVES THE COPYRIGHT AND OTHER RIGHTS RESTRICTING THESE DOCUMENTS TO THE ORIGINAL SITE OR PURPOSE FOR WHICH THEY WERE PREPARED. REPRODUCTIONS, CHANGES OR ASSIGNMENTS ARE PROHIBITED.

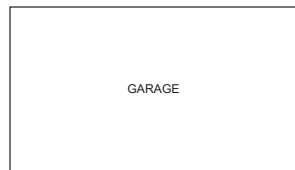
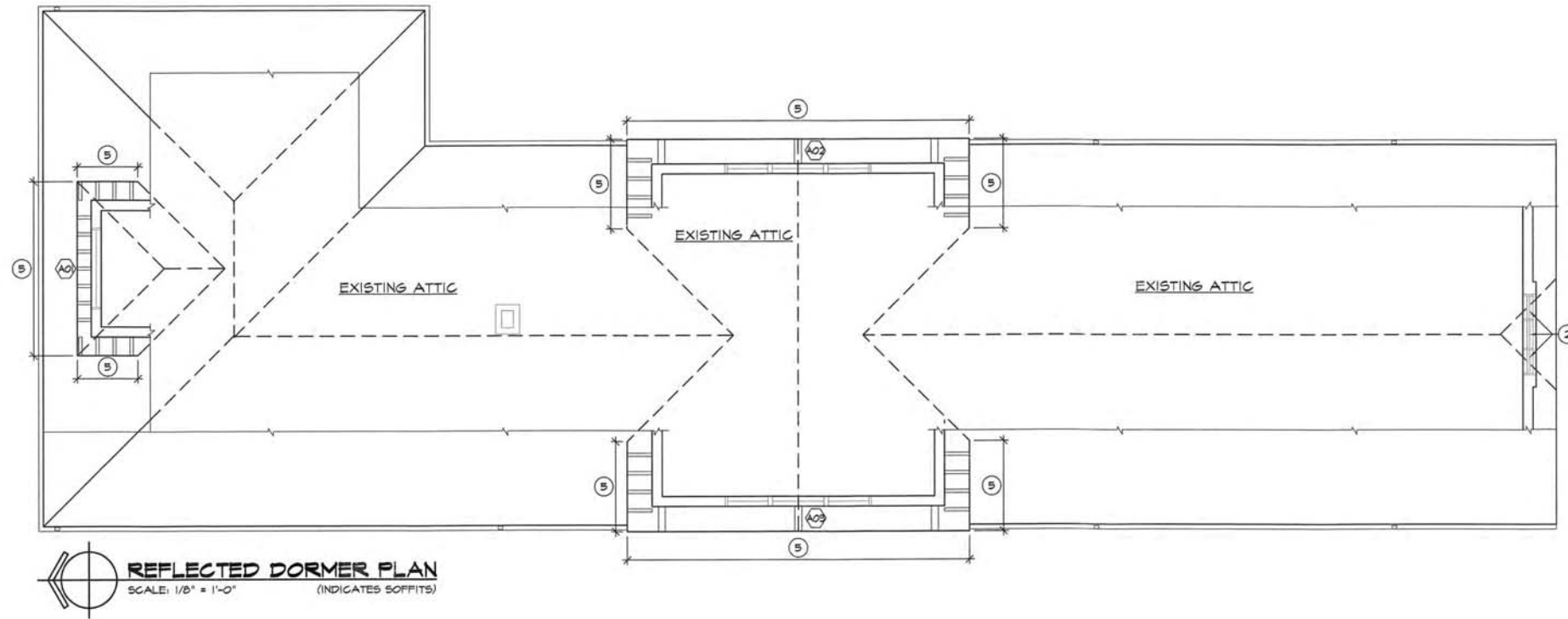

SYMBOL LEGEND

SEE ELECTRICAL LIGHTING SHEETS FOR FIXTURE TYPES.
SEE MECHANICAL SHEETS FOR EXHAUST FAN SIZES.

- RECESSED 2x4 TROFFER
- SURFACE MOUNTED 2x4 TROFFER
- RECESSED CEILING LIGHT
- RECESSED WALL/WASH CEILING LIGHT
- CEILING MOUNTED EXIT LIGHT
- SHADING INDICATES FACE DIRECTION
- WALL MOUNTED EXIT LIGHT
- EXHAUST FAN
- SUPPLY DIFFUSER
- RETURN DIFFUSER
- SURFACE/WALL MOUNTED STRIP FIXTURES
- CEILING MOUNTED FIXTURE
- WALL MOUNTED FIXTURE

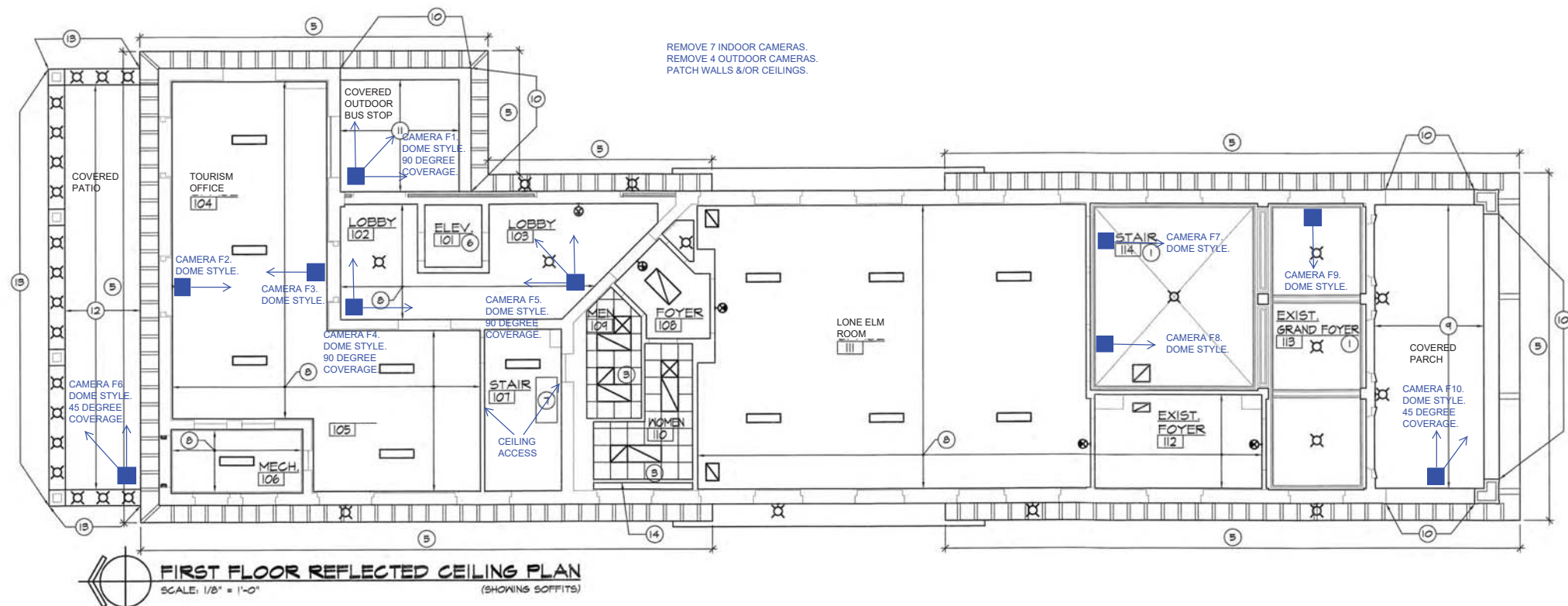

PROJ. 01026-4

HUA architects
Hance, Utz & Associates, P.C. License No. 104-001979 1019 South Nineteenth Street, Mattoon, Illinois 61938 Tel.: (217) 235-4101 Fax: (217) 235-4103 E-mail: info@hanceutz.com













JOB NO. 01026-4	REMODELLING FOR: I.C.R.R. DEPOT	REVISIONS:	DATE:	SHEET NO. 2
DATE: MARCH 22, 2007	1709 BROADWAY AVENUE MATTOON, ILLINOIS			FIRST FLOOR REFLECTED CEILING PLAN & NOTES
SCALE: AS SHOWN				
DRAWN: PAC	CHECKED: DDH			

#01026-4 I.C.R.R. DEPOT - MATTOON, ILLINOIS

COPYRIGHT © 2007 HANCE, UTZ & ASSOCIATES, P.C. RESERVES THE COPYRIGHT AND OTHER RIGHTS RESTRICTING THESE DOCUMENTS TO THE ORIGINAL SITE OR PURPOSE FOR WHICH THEY WERE PREPARED. REPRODUCTIONS, CHANGES OR ASSIGNMENTS ARE PROHIBITED.

SYMBOL LEGEND

SEE ELECTRICAL LIGHTING SHEETS FOR FIXTURE TYPES.
SEE MECHANICAL SHEETS FOR EXHAUST FAN SIZES.

-  RECESSED 2x4 TROUFFER
-  SURFACE MOUNTED 2x4 TROUFFER
-  RECESSED CEILING LIGHT
-  RECESSED WALL/WASH CEILING LIGHT
-  CEILING MOUNTED EXIT LIGHT
SHADING INDICATES FACE DIRECTION
-  WALL MOUNTED EXIT LIGHT
-  EXHAUST FAN
-  SUPPLY DIFFUSER
-  RETURN DIFFUSER
-  SURFACE/WALL MOUNTED STRIP FIXTURES
-  SURFACE/WALL MOUNTED STRIP FIXTURES
-  CEILING MOUNTED FIXTURE
-  WALL MOUNTED FIXTURE

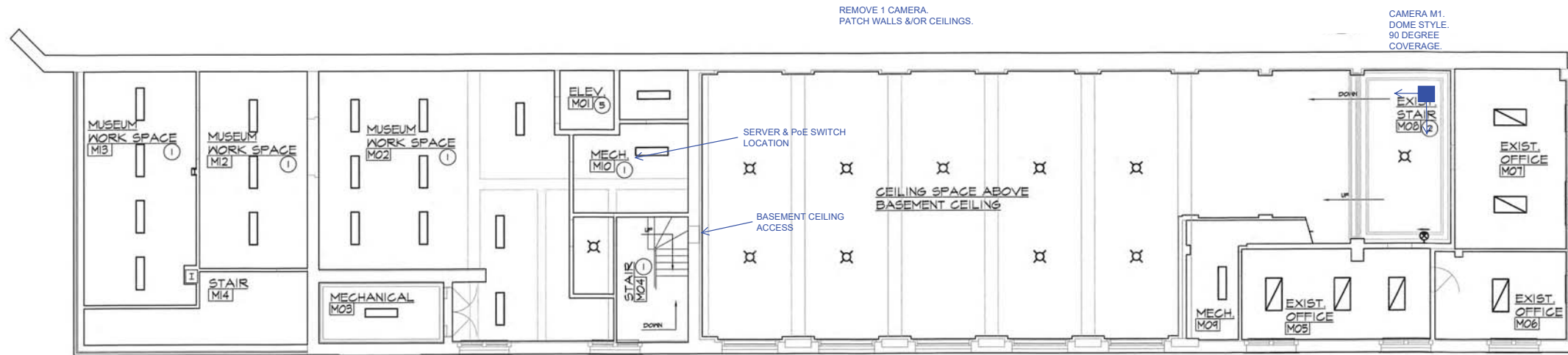

MEZZANINE REFLECTED CEILING PLAN
SCALE: 1/8" = 1'-0"

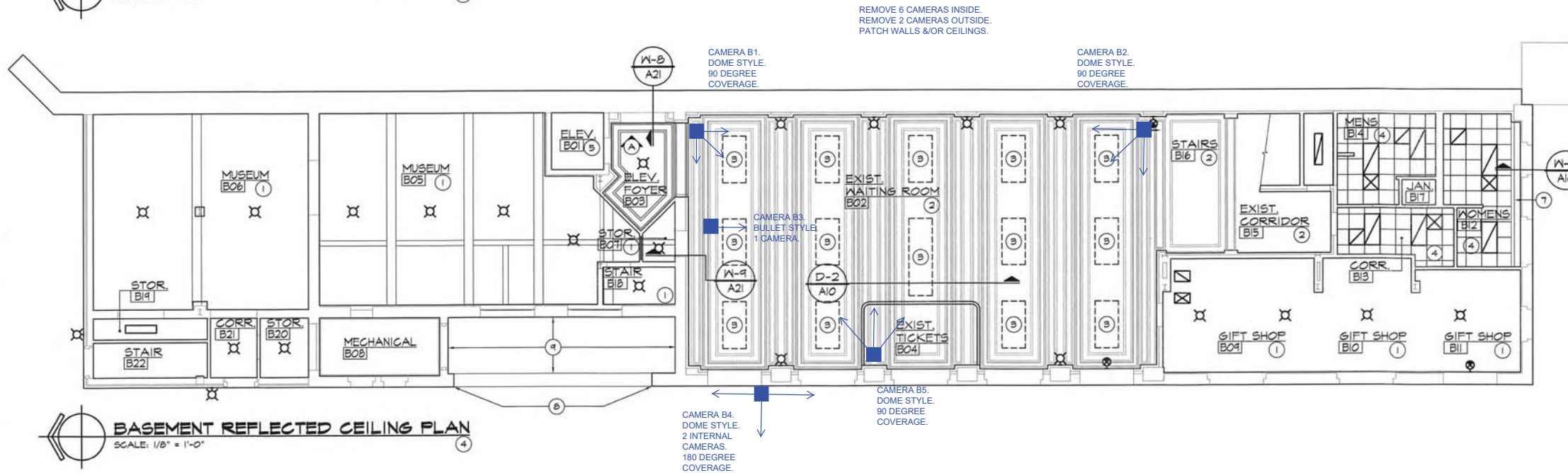

BASEMENT REFLECTED CEILING PLAN
SCALE: 1/8" = 1'-0"

DEPOT CAMERAS

TRAIN DEPOT
1718 BROADWAY AVE

POINT TO POINT
RECEIVER.
MOUNT IN
ATTIC WINDOW.

CAMERA HP1.
BULLET STYLE.
45 DEGREE COVERAGE.

BROADWAY AVE

HERITAGE PARK
1701 BROADWAY

PAVILION

17TH STREET

PROGRESS SQUARE
1621 BROADWAY AVE

CAMERA PS1.
DOME STYLE.
90 DEGREE COVERAGE.

INSTALL 2 PORT PoE SWITCH
IN EXIST CONTROL PANEL.
CONNECT POWER TO
CIRCUIT BREAKER IN
ADJACENT PANELBOARD.

MOUNT POINT TO POINT
TRANSMITTER ADJACENT
TO CAMERA ON WALL.



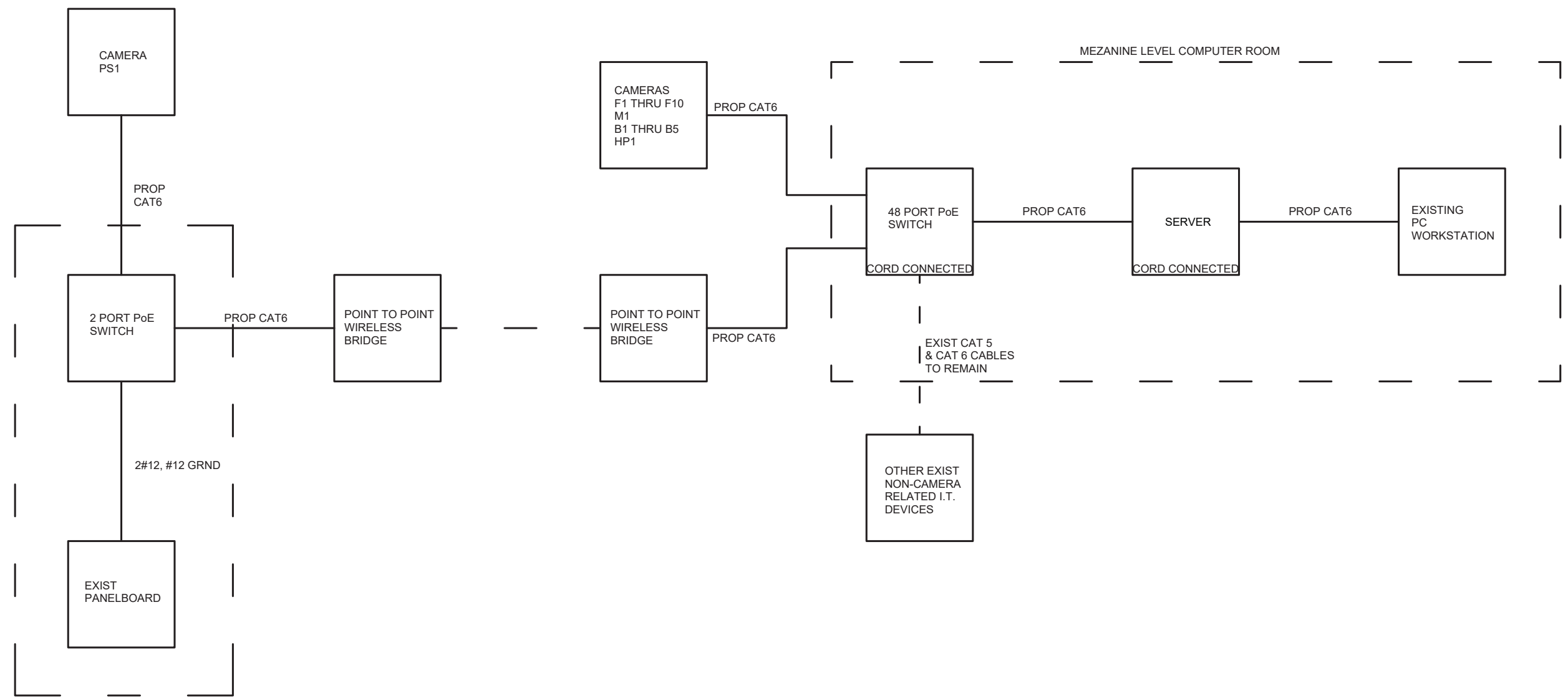

- NOTES:
1. ALL PoE/DATE CABLES SHALL BE CAT 6. ALL 120V POWER CABLES SHALL BE THWN-2 (90°C).
 2. EXPOSED CABLES SHALL BE IN CONDUIT.
 3. CONDUIT IS NOT REQUIRED IN CONCEALED AREAS SUCH AS CRAWL SPACES AND ATTICS.
 4. INDOOR CONDUIT SHALL BE EMT OR RIGID METAL CONDUIT (STEEL OR ALUMINUM).
 5. OUTDOOR CONDUIT SHALL BE GRS WITH THREADED JOINTS, OR ALUMINUM WITH THREADED JOINTS.

EXIST CONTROL
PANEL & PANELBOARD
PROGRESS SQUARE

CITY OF MATTOON, ILLINOIS

RESOLUTION NO. 2021-3169

DECLARATION OF LOCAL STATE OF EMERGENCY

State of Illinois
County of Coles
City of Mattoon

Pursuant to the authority vested in the office of Mayor by the Illinois Municipal Code Section 5/11-1-6, the Illinois Emergency Management Agency Act Section 3305/11 and Ordinance No. 2020-5430 of the City of Mattoon, I, Rick Hall, Mayor of the City of Mattoon do hereby declare that a Local State of Emergency exists as of this date, December 21, 2021, and shall continue until such time as provided in Ordinance No. 2020-5430.

WHEREAS, on January 30, 2020, the World Health Organization declared the outbreak of COVID-19 to be a public health emergency of international concern and on March 11, 2020 declared a worldwide pandemic; and

WHEREAS, on January 31, 2020, the U.S. Health and Human Services Secretary declared a public health emergency for the United States; and

WHEREAS, the Governor of the State of Illinois has issued a disaster proclamation on March 9, 2020 due to the impact of the COVID-19 virus and has activated the State Emergency Operations Center; and

WHEREAS, the State Emergency Management Agency has declared a public health emergency due to the impact of the COVID-19 virus; and

WHEREAS, the City Administration has coordinated its response with other Coles County governmental entities.

The nature of the emergency is related to the COVID-19 virus which is causing or anticipated to cause widespread impacts on the health of members of the community.

During the existence of the Local State of Emergency, the Mayor shall execute such authority as provided under the Illinois Municipal Code, the Illinois Emergency Management Agency Act and Ordinance No. 2020-5430.

This Declaration of Local State of Emergency shall be filed with the City Clerk as soon as practicable.

I, Rick Hall, whose name is signed to this instrument, being first duly sworn, signed and executed the instrument as the Declaration of Local State of Emergency, and that I signed willingly, and that I executed it as my free and voluntary act for the purposes therein expressed.

Rick Hall, Mayor
City of Mattoon, Coles County, Illinois

Nothing follows